



ISO/TC 197
Hydrogen technologies

Email of secretary: jim.ferrero@bnq.gc.ca
Secretariat: SCC (Canada)

TC 197 WG 25 CD 16111 for Ballot 2016 04 11

Document type: CD ballot

Date of document: 2016-04-11

Expected action: COMM

Action due date: 2016-06-12

Background: This is the ISO/CD 16111 *Transportable gas storage devices – Hydrogen absorbed in reversible metal hydride* that was prepared by WG 25 for the revision of this standard.

The main purpose of the CD Ballot is to get comments that will be treated prior to the DIS Ballot.

Note that the main modifications are highlighted in yellow and there are three new annexes (E, F and G).

Committee URL: <http://isotc.iso.org/livelink/livelink/open/tc197>

1	ISO TC 197
2	Date : 2016-04-11
3	ISO/CD 16111
4	ISO/TC 197/WG 25
5	Secretariat: SCC

6 **Transportable gas storage devices — Hydrogen absorbed in reversible metal hydride**

7 *Appareils de stockage de gaz transportables — Hydrogène absorbé dans un hydrure métallique*
8 *réversible*

9

Copyright notice

This ISO document is a Draft Standard and is copyright-protected by ISO. Except as permitted under the applicable laws of the user's country, neither this ISO draft nor any extract from it may be reproduced, stored in a retrieval system or transmitted in any form or by any means, electronic, photocopying, recording or otherwise, without prior written permission being secured.

Requests for permission to reproduce should be addressed to either ISO at the address below or ISO's member body in the country of the requester.

ISO copyright office
Case postale 56 • CH-1211 Geneva 20
Tel. + 41 22 749 01 11
Fax + 41 22 749 09 47
E-mail copyright@iso.org
Web www.iso.org

Reproduction may be subject to royalty payments or a licensing agreement.

Violators may be prosecuted.

11	Contents		Page
12	1	Scope	1
13	2	Normative references	1
14	3	Terms and definitions	2
15	4	Service conditions	4
16	4.1	Pressures	4
17	4.2	Rated capacity	4
18	4.3	Temperature ranges	5
19	4.4	Environmental conditions	5
20	4.5	Service life	5
21	4.6	Hydrogen quality	5
22	4.7	Special service conditions	5
23	5	Design considerations	5
24	5.1	General	5
25	5.2	Material selection	5
26	5.3	Shell design	6
27	5.4	Design strength	7
28	5.5	Overpressure and fire protection	7
29	5.6	Loading of hydrogen absorbing alloy	8
30	5.7	Shut-off valves	8
31	5.8	Actively cooled MH assemblies	10
32	5.9	Particulate containment	10
33	6	Inspection and testing	10
34	6.1	General	10
35	6.2	Type/qualification tests	10
36	6.3	Batch tests	23
37	6.4	Routine tests and inspections	24
38	7	Marking, labelling, and documentation	24
39	7.1	Marking	24
40	7.2	Labelling	25
41	8	Documentation accompanying the product	25
42	8.1	Material safety data sheets	25
43	8.2	User's or operating manual	26
44	Annex A (informative)	Material compatibility for hydrogen service	27
45	A.1	Material compatibility for hydrogen service	27
46	A.2	Metals and metallic materials	27
47	A.3	Polymers, elastomers and other non-metallic materials	28
48	A.4	Other references	29
49	Annex B (normative)	Environmental tests	30
50	B.1	Exposure to fluids	30
51	B.2	Salt water immersion test	34
52	Annex C (informative)	Type approval certificate	35
53	Annex D (informative)	Acceptance certificate	37
54	Annex E (informative)	Shell having internal volume greater than 150L	40
55	Annex F (informative)	Fixed fuel-storage onboard hydrogen fueled vehicles	41
56	Annex G (informative)	Stationary application	42

57 Foreword

58 ISO (the International Organization for Standardization) is a worldwide federation of national standards bodies
59 (ISO member bodies). The work of preparing International Standards is normally carried out through ISO
60 technical committees. Each member body interested in a subject for which a technical committee has been
61 established has the right to be represented on that committee. International organizations, governmental and
62 non-governmental, in liaison with ISO, also take part in the work. ISO collaborates closely with the
63 International Electrotechnical Commission (IEC) on all matters of electrotechnical standardization.

64 International Standards are drafted in accordance with the rules given in the ISO/IEC Directives, Part 2.

65 The main task of technical committees is to prepare International Standards. Draft International Standards
66 adopted by the technical committees are circulated to the member bodies for voting. Publication as an
67 International Standard requires approval by at least 75 % of the member bodies casting a vote.

68 Attention is drawn to the possibility that some of the elements of this document may be the subject of patent
69 rights. ISO shall not be held responsible for identifying any or all such patent rights.

70 ISO 16111 was prepared by Technical Committee ISO/TC 197, *Hydrogen technologies*, with participation by
71 Technical Committee ISO/TC 58, *Gas cylinders*, Subcommittee SC 3, *Cylinder design*.

72 This second edition cancels and replaces ISO16111:2008, which has been technically revised.

73 Introduction

74 As the utilization of gaseous hydrogen evolves from the chemical industry into various emerging applications,
75 such as fuel for fuel cells and internal combustion engines and other specialty hydrogen applications, the
76 importance of new and improved storage techniques has become essential. One of these techniques employs
77 the absorption of hydrogen into specially formulated alloys. The material can be stored and transported in a
78 solid form, and the hydrogen later released and used under specific thermodynamic conditions. This
79 International Standard describes the service conditions, design criteria, type tests, batch tests and routine test
80 for transportable hydrogen storage systems based on hydrogen absorbing materials. Independently from the
81 chemical or physical bounding nature of hydrogen with its absorbing material, we will refer to the systems as
82 "metal hydride assemblies" (MH assemblies) for simplicity. Types of MH assemblies may serve as: fuel cell
83 cartridges; hydrogen fuel storage containers; high-purity hydrogen supplies and others.

84

1 Transportable gas storage devices — Hydrogen absorbed in 2 reversible metal hydride

3 1 Scope

4 This International Standard defines the requirements applicable to the material, design, construction, and
5 testing of transportable hydrogen gas storage systems, referred to as “metal hydride assemblies” (MH
6 assemblies) which utilize shells not exceeding 150 l internal volume and having a maximum developed
7 pressure (MDP) not exceeding 25 MPa (250 bar). This International Standard only applies to refillable storage
8 MH assemblies where hydrogen is the only transferred media. Storage MH assemblies intended to be used as
9 fixed fuel-storage onboard hydrogen fuelled vehicles are excluded. This International Standard is intended to
10 be used for certification purposes.

11 **NOTE** For systems which are not cover by the scope of this standard, see informative annex E,F and G for
12 guidelines on some applications.

13 2 Normative references

14 The following referenced documents are indispensable for the application of this document. For dated
15 references, only the edition cited applies. For undated references, the latest edition of the referenced
16 document (including any amendments) applies.

17 ISO 7225, *Gas cylinders — Precautionary labels*

18 ISO 7866, *Gas cylinders — Refillable seamless aluminium alloy gas cylinders — Design, construction and
19 testing*

20 ISO 9809-1, *Gas cylinders — Refillable seamless steel gas cylinders — Design, construction and testing —
21 Part 1: Quenched and tempered steel cylinders with tensile strength less than 1 100 MPa*

22 ISO 9809-2, *Gas cylinders — Refillable seamless steel gas cylinders — Design, construction and testing —
23 Part 2: Quenched and tempered steel cylinders with tensile strength greater than or equal to 1 100 MPa*

24 ISO 9809-3, *Gas cylinders — Refillable seamless steel gas cylinders — Design, construction and testing —
25 Part 3: Normalized steel cylinders*

26 ISO 10297, *Transportable gas cylinders — Cylinder valves — Specification and type testing*

27 ISO 10961 Gas cylinders -- Cylinder bundles -- Design, manufacture, testing and inspection

28 ISO 11114-4, *Transportable gas cylinders — Compatibility of cylinder and valve materials with gas contents —
29 Part 4: Test methods for selecting metallic materials resistant to hydrogen embrittlement*

30 ISO 11119-1, *Gas cylinders of composite construction — Specification and test methods — Part 1: Hoop
31 wrapped composite gas cylinders*

32 ISO 11119-2, *Gas cylinders of composite construction — Specification and test methods — Part 2: Fully
33 wrapped fibre reinforced composite gas cylinders with load-sharing metal liners*

34 ISO 11119-3, *Gas cylinders of composite construction — Specification and test methods — Part 3: Fully
35 wrapped fibre reinforced composite gas cylinders and tubes up to 450L with non-load-sharing metallic or non-
36 metallic liners*

1 ISO 11120, *Gas cylinders Refillable seamless steel tubes of water capacity between 150 l and 3000 l -Design,*
2 *construction and testing*

3 ISO 11515 : *Gas cylinders -- Refillable composite reinforced tubes of water capacity between 450 L and 3000*
4 *L - Design, construction and testing*

5 ISO 14246, *Transportable gas cylinders — Gas cylinder valves — Manufacturing tests and inspections*

6 ISO 14687, *Hydrogen fuel — Product specifications*

7 ISO 16528-1, *Boilers and pressure vessels — Part 1: Performance requirements*

8 UN Recommendations on the Transport of Dangerous Goods. Model Regulations

9 UN Global Technical Regulation No.13 (Hydrogen and fuel cell vehicles)

10 3 Terms and definitions

11 For the purposes of this document, the following terms and definitions apply.

12 3.1

13 **absorbed**

14 taken and held through the formation of bonding interactions within the bulk of the material

15 3.2

16 **burst pressure**

17 highest pressure reached in an MH assembly during a burst test

18 3.3

19 **design stress limit**

20 total stress loading allowed on the shell wall

21 NOTE In MH assemblies, the shell design takes into account the gas pressure plus other stresses, such as pressure
22 exerted by expansion of the hydrogen absorbing alloy.

23 3.4

24 **fuel cell cartridge**

25 MH assembly , which stores hydrogen for use as a fuel in a fuel cell or article that stores fuel for discharge into
26 the fuel cell through a valve(s) that controls the discharge of fuel into the fuel cell

27 3.5

28 **full flow capacity pressure**

29 gas pressure at which the pressure relief device is fully open

30 3.6

31 **hydrogen absorbing alloy**

32 material capable of combining directly with hydrogen gas to form a reversible metal hydride

33 3.7

34 **internal component**

35 structure, matrix, material or device contained within the shell (excluding hydrogen gas, hydrogen absorbing
36 alloy and metal hydride)

37 NOTE Internal components may be used for purposes such as heat transfer, preventing movement of the hydrogen
38 absorbing alloy/metal hydride and/or to prevent excessive stress on the shell walls due to hydride expansion.

39 3.8

40 **internal volume**

41 water capacity of the shell

1 **3.9**
 2 **maximum developed pressure**
 3 **MDP**
 4 highest gas gauge pressure for an MH assembly at rated capacity which can be reached either in the normal
 5 service conditions or in the normal operating conditions

6 NOTE The MDP term was specifically selected for MH assemblies to avoid confusion with the MAWP and the service
 7 pressure used in other ISO International Standards.

8 **3.10**
 9 **metal hydride**
 10 solid material formed by reaction between hydrogen and hydrogen absorbing alloy

11 **3.11**
 12 **metal hydride assembly**
 13 **MH assembly**
 14 single complete hydrogen storage system, including shell, metal hydride, pressure relief device (PRD),
 15 shut-off valve, other appurtenances and internal components

16 NOTE 1 The MH assembly extends only to, and includes, the first shut-off valve.

17 NOTE 2 A fuel cell cartridge is a type of MH assembly.

18 **3.12**
 19 **bundle of MH Assemblies**
 20 A set of MH assemblies connected together by pipes.

21 **3.13**
 22 **normal operating conditions**
 23 range of pressures, MH assembly external shell temperatures, hydrogen flow rates, hydrogen quality, etc.,
 24 specified for all use and filling operations

25 **3.14**
 26 **normal service conditions**
 27 range of pressures, environmental temperatures, specified for transportation and storage conditions

28 **3.15**
 29 **pressure relief device**
 30 **PRD**
 31 device intended to prevent the rupture of an MH assembly in the event of overpressure or exposure to fire

32 NOTE A pressure relief device may be “pressure-activated”, set to activate at a certain pressure. Alternatively, a
 33 pressure relief device may be “thermally-activated”, set to activate at a certain temperature. A pressure relief device may
 34 also be both “pressure-activated” and “thermally-activated”.

35 **3.16**
 36 **pressure relief valve**
 37 **PRV**
 38 reseatable PRD

39 **3.17**
 40 **rated capacity**
 41 maximum quantity of hydrogen deliverable under specified conditions

42 **3.18**
 43 **rated charging pressure**
 44 **RCP**
 45 maximum pressure to be applied to the MH assembly for refilling

46 NOTE The RCP is not necessarily equal to the equilibrium plateau pressure of the hydrogen absorbing alloy.

1 **3.19**
2 **reversible metal hydride**
3 metal hydride for which there exists an equilibrium condition where the hydrogen absorbing alloy, hydrogen
4 gas and the metal hydride co-exist

5 NOTE Changes in pressure or temperature will shift the equilibrium favouring the formation or decomposition of the
6 metal hydride with respect to the hydrogen absorbing alloy and hydrogen gas.

7 **3.20**
8 **rupture**
9 structural failure of a shell resulting in the sudden release of stored energy

10 **3.21**
11 **shell**
12 enclosure of any shape (cylindrical, prismatic, cubic, etc.) designed to contain the hydrogen gas, metal
13 hydride and other internal components of the MH assembly

14 NOTE A shell may be a gas cylinder, a pressure vessel or other type of container.

15 **3.22**
16 **stress level at MDP**
17 sum of all the stresses on the shell wall caused by the metal hydride at rated capacity, hydrogen gas at MDP
18 and any other applicable mechanical loadings

19 **3.23**
20 **test pressure**
21 required pressure applied during a pressure test for qualification

22 **4 Service conditions**

23 **4.1 Pressures**

24 **4.1.1 Maximum developed pressure (MDP)**

25 The MDP shall be determined by the manufacturer from the metal hydride's temperature–pressure
26 characteristics. In no case shall the MDP exceed 0.8 times the test pressure of the shell. The MDP shall not
27 exceed 25 MPa (250 bar).

28 **4.1.2 Rated charging pressure (RCP)**

29 The RCP shall be specified by the manufacturer in order to prevent charging at a pressure that could result in
30 the shell wall stress exceeding the design stress limit.

31 **4.1.3 Stress level at MDP**

32 The stress level at MDP shall be determined by the manufacturer from the hydrogen absorbing alloy's packing
33 and expansion properties, the MDP within the MH assembly, and other applicable mechanical loadings.

34 **4.2 Rated capacity**

35 The manufacturer shall state the rated capacity of the MH assembly by units of mass of hydrogen.

1 4.3 Temperature ranges

2 4.3.1 Operating temperature range

3 The minimum and maximum MH assembly temperature for normal operating conditions shall be specified by
4 the manufacturer.

5 4.3.2 Service temperature range

6 The minimum and maximum ambient shell temperature for normal service conditions shall be specified by the
7 manufacturer, if different from respectively $-40\text{ }^{\circ}\text{C}$ for the minimum and $+65\text{ }^{\circ}\text{C}$ for the maximum.

8 4.4 Environmental conditions

9 The MH assemblies are expected to be exposed to a number of environmental conditions over their service
10 life, such as vibration and shock, varying humidity levels, and corrosive environments. The manufacturer shall
11 specify the environmental conditions for which the MH assembly was designed.

12 4.5 Service life

13 The service life for the MH assemblies shall be specified by the manufacturer on the basis of use under
14 service conditions specified herein. The service life shall not exceed that specified by the standard to which
15 the shell is designed as per 5.3.

16 4.6 Hydrogen quality

17 The minimum quality of the hydrogen gas that shall be used to fill an MH assembly shall be specified by the
18 manufacturer according to ISO 14687 or as appropriate.

19 NOTE If the quality of the hydrogen gas is considered a critical issue to avoid performance degradation of the MH
20 assembly, the manufacturer may consider including the information on the product label.

21 4.7 Special service conditions

22 Any additional service conditions that shall be met for the safe operation, handling and usage of the MH
23 assembly shall be specified by the manufacturer.

24 5 Design considerations

25 5.1 General

26 The MH assembly shall be designed and constructed to prevent leakage of free hydrogen gas or metal
27 hydride particles under normal service and operating conditions.

28 5.2 Material selection

29 5.2.1 General

30 The MH assembly components shall be made of materials that are suitable for the range of conditions
31 expected over the life of the MH assembly. Components that are in contact with gaseous hydrogen and/or
32 metal hydride material shall be sufficiently resistant to their chemical and physical action under normal service
33 or operating conditions to maintain operational and pressure containment integrity.

34 Hydrogen absorbing alloys and/or metal hydride materials that are classified as class 2.1 flammable according
35 to the UN Recommendations on the Transport of Dangerous Goods shall not be used in an MH assembly.

5.2.2 External surfaces

The MH assembly shell, shut-off valve, PRDs and other appurtenances shall be resistant to the environmental conditions specified in 4.4. Resistance to these environmental conditions may be provided by using materials inherently resistant to the environment or by applying resistant coatings to the components. Exterior protection may be provided by using a surface finish giving adequate corrosion protection (e.g. metal sprayed on aluminium or anodizing) or a protective coating (e.g. organic coating or paint). If an exterior coating is part of the design, the coating shall be evaluated using the applicable test methods specified in Annex B. Any coatings applied to MH assemblies shall be such that the application process does not adversely affect the mechanical properties of the shell or performance and operation of other components. The coatings shall be designed to facilitate subsequent in-service inspection and the manufacturer shall provide guidance on coating treatment during such inspections to ensure the continued integrity of the MH assembly.

5.2.3 Compatibility

The compatibility of MH assembly materials with process fluids and solids, specifically embrittlement due to the exposure to hydrogen, shall be considered. Guidance on compatibility of materials with gases is given in ISO 11114-1 and ISO 11114-2. Materials necessary for the pressure containment and structural integrity of the MH assembly and its internal and external appurtenances shall be resistant to hydrogen embrittlement, hydrogen attack and reactivity with contained materials and maintain their integrity for the service life of the MH assembly. Recognized test methods, such as those specified in ISO 11114-4, shall be used to select metallic materials resistant to hydrogen embrittlement where required for pressure or structural integrity. Consideration shall be given to the impact that temperature may have on hydrogen embrittlement.

Consideration shall be given to all of the chemical species that may be present during the charged, partially charged and discharged states and their potential reactivity with the MH assembly material. The MH assembly materials shall be selected so as the combination does not endanger the MH assembly integrity.

NOTE The susceptibility to hydrogen embrittlement of some commonly used metals is summarized in ISO/TR 15916. Additional guidance regarding hydrogen compatibility is found in Annex A.

5.2.4 Temperature

The MH assembly materials shall be suitable for the service temperature range specified in 4.3.1 and 4.3.2.

5.3 Shell design

5.3.1 Shells with internal volume greater than 120 ml

The MH assembly shell shall be designed and tested according to ISO 7866, ISO 9809-1, ISO 9809-3, ISO 11119-1, ISO 11119-2, ISO 11119-3 or for design or shape shell not cover by the previous standards the manufacturer must prove their performance in accordance to ISO 16528-1. Shells designed and tested in accordance with ISO 9809-1 shall have a tensile strength less than 950 MPa. Shells designed and tested in accordance with ISO 11119-1 or ISO 11119-2 that use seamless steel liners conforming to ISO 9809-2 or to ISO 9809-1 shall have a tensile strength less than 950 MPa. Shells designed with proof of performance according to ISO16528-1 are considered as pressure vessels.

The shell shall not exceed 150 l internal volume, and the MDP shall not exceed 25 MPa (250 bar). The maximum combined stresses for the loads described in 5.4 as well as the operating and service temperature ranges for the MH assembly shall not exceed the limits prescribed by the standard to which the shell is designed.

NOTE 1 Shells can be designed and tested according to one of the International Standards specified above, even where the shell internal volume is less than that covered by the scope of that International Standard.

NOTE 2 An equivalent gas pressure calculated to be equal to the stress level at MDP can be used as the design hydraulic test pressure for determining minimum shell wall thickness.

1 5.3.2 Shells with internal volume of 120 ml or less

2 For MH assemblies with an internal volume of 120 ml or less, the shell design shall be deemed to be
3 appropriate if the shell meets 5.3.1 or the MH assembly meets the following design and test criteria:

- 4 a) the pressure in the MH assembly shall not exceed 5 MPa (50 bar) at 55 °C when the MH assembly is
5 filled to its rated capacity; and
- 6 b) the MH assembly design shall withstand as required by 6.2.3, without leaking or bursting, a minimum
7 shell burst pressure of 2 times the pressure in the MH assembly at 55 °C when filled to rated capacity, or
8 1.6 times the pressure in the MH assembly at the maximum service temperature when filled to rated
9 capacity, or 200 kPa (2 bar) more than the MDP of the assembly at 55 °C when filled to rated capacity,
10 whichever is greater.

11 5.4 Design strength

12 The shell design shall take into account the stress level at 1.25 times MDP. Consideration of components
13 contributing to the stress level at MDP shall include but not be limited to:

- 14 — $1.25 \times \text{MDP}$;
- 15 — thermal stress, including dissimilar rates of thermal expansion and contraction;
- 16 — weight of internals in any possible MH assembly orientation;
- 17 — shock and vibration loading;
- 18 — maximum stress due to hydrogen absorbing alloy expansion;
- 19 — other mechanical loadings.

20 To verify that the design stress limit is not exceeded, the MH assembly design shall be subjected to the
21 hydrogen cycling and strain measurement test described in 6.2.6.

22 NOTE The process of introducing and subsequently removing hydrogen in the hydrogen absorbing alloy typically
23 causes it to expand and contract. In turn, this can result in large stresses inside the alloy's particles that cause them to
24 fragment into smaller particles, a phenomenon known as decrepitation. After several charge/discharge cycles, the average
25 particle size may have significantly decreased. Stresses on the MH assembly walls may be derived from expansion of the
26 hydrogen absorbing alloy during hydrogenation and from changes in the packing configuration due to decrepitation over
27 the service life of the MH assembly. The magnitude of the expansion/contraction phenomena will vary greatly as a function
28 of the hydrogen absorbing alloy used.

29 5.5 Overpressure and fire protection

30 5.5.1 General

31 The MH assembly shall be protected with one or more PRDs of the non-reclosing type, such as thermally
32 activated PRD, rupture disks and diaphragms, or of the re-sealable type, such as spring-loaded PRVs. The
33 MH assembly and any added component (e.g. insulation or protective material) shall collectively pass the fire
34 test specified in 6.2.2. The PRD shall conform to the requirements of 5.5.2 and 5.5.3 and the additional
35 requirements of the competent authority of country of use, as applicable.

36 For MH assemblies with an internal volume of 120 ml or less, other means may be used to protect from
37 overpressurization, such as venting through a feature integral to the shell. MH assemblies that use an
38 alternative means of relieving pressure shall meet the acceptance criteria of the fire test specified in 6.2.2.

5.5.2 PRD activation pressure

The pressure of actuation of pressure-activated PRDs shall be specified by the manufacturer and shall be greater than the MDP but less than 1,25 times the MDP. In no case shall the pressure of actuation of a pressure-activated PRD exceed the test pressure of the shell. For PRVs, the full flow capacity pressure shall also be specified, and shall not exceed the test pressure of the shell.

5.5.3 PRD activation temperature

The temperature at which any thermally activated PRD is set to activate shall be specified by the manufacturer and correspond to an equilibrium pressure inside the MH assembly of less than 1.25 times the MDP. In no case shall the temperature of actuation of a temperature-activated PRD result in an equilibrium pressure inside the MH assembly that exceeds the test pressure of the shell. The PRD shall have a pressure rating greater than the MDP at all temperatures less than or equal to 10 °C above the maximum service temperature or operating temperature (whichever is higher). In no case shall the PRD activate at a temperature lower than the maximum service or operating temperature.

NOTE Due to the MDP definition, an equilibrium pressure less than 1.25 times the MDP is compliant with 4.1.1 and 5.4, which respectively refer to the MDP assessment and the shell design. As an immediate consequence, the pressure inside the MH assembly cannot exceed the test pressure of the shell at the temperature of actuation.

5.6 Loading of hydrogen absorbing alloy

Procedures and verification testing shall be put in place to ensure the consistent loading of the hydrogen absorbing alloy/metal hydride in the MH assembly.

5.7 Shut-off valves

5.7.1 General

The MH assembly shall incorporate a shut-off valve that shall be capable of being closed when the MH assembly is disconnected from the refill or gas-consuming equipment. The shut-off valve may be manually actuated, such as by a handwheel, or automatically actuated.

All MH assemblies shall provide a means of shut-off valve protection that complies with 5.7.4 or 5.7.5.

The shut-off valve selection shall include verification that the shut-off valve seal is maintained with vacuum conditions within the MH assembly.

NOTE Due to the temperature/pressure characteristics of metal hydrides, the development of sub-ambient pressures is possible within MH assemblies.

5.7.2 MH assemblies with internal volume greater than 120 ml

Shut-off valves shall comply with ISO 10297, or equivalent, with the following adjustment:

- a) 3 times MDP shall be used as the resistance pressure for the valve;
- b) Valve test pressure, p_{vt} , shall be equal to 1.5 times the MDP;
- c) Gas pressure for endurance test shall be equal to 0.5 times the MDP.

In addition, the shut-off valve shall meet all requirements and tests prescribed in this International Standard.

Alternatively, if the shut-off valve cannot demonstrate full compliance to ISO 10297 or equivalent, the shut-off valve construction and performance shall meet all the requirements and tests prescribed in this International Standard as well as the following requirements:

- 1 — the material requirements of ISO 10297, 4.3;
- 2 — the test requirements of ISO 10297, 6.1 to 6.8, as they apply to the tests prescribed below with the
3 exception the valve test pressure, p_{vt} , shall be equal to 1.5 times the MDP;
- 4 — the hydraulic pressure test of ISO 10297, 6.9, with the exception that 3 times the MDP shall be used as
5 the test pressure;
- 6 — the leak tightness test of ISO 10297, 6.11, where p_{vt} shall be equal to 1.5 times the MDP;
- 7 — the endurance test of ISO 10297, 6.12, using a gas pressure equal to 0.5 times the MDP. When the shut-
8 off valve does not incorporate a handwheel, the forces and torques used in the endurance test shall be
9 representative of those used in service to open and close the valve member. Prior to and following the
10 endurance test, the shut-off valve shall be tested for leakage from an internal and external leakage
11 perspective at a test pressure of 1,5 times MDP at minimum and maximum service temperature. Leakage
12 rates less than or equal to 6 standard cm^3/h (standard conditions of 0 °C and 101.325 kPa absolute) shall
13 be acceptable.
- 14 The minimum rated pressure of the shut-off valve shall be at least equal to 1,5 times MDP.
- 15 In addition, the shut-off valve manufacturer shall demonstrate that the shut-off valve is subjected to the
16 requirements of ISO 14246.

17 5.7.3 MH assemblies with internal volume of 120 ml or less

- 18 For MH assemblies with an internal volume of 120 ml or less, the shut-off valve construction and performance
19 shall meet all requirements and tests prescribed in this International Standard as well as the following
20 requirements:
- 21 — the material requirements of ISO 10297, 4.3;
- 22 — the test requirements of ISO 10297, 6.1 to 6.8, as they apply to the tests prescribed below with the
23 exception that the valve test pressure, p_{vt} , shall be equal to 1.5 times the MDP;
- 24 — the hydraulic pressure test of ISO 10297, 6.9, with the exception that the test pressure shall be in
25 accordance with 5.3.2 b) and the test may be performed pneumatically;
- 26 — the leak tightness test of ISO 10297, 6.11, where p_{vt} shall be equal to 1.5 times the MDP. Valve closure
27 may be determined using torque, compression or other suitable means and the test gas shall be helium;
- 28 — the endurance test of ISO 10297, 6.12, using a gas pressure equal to 0.5 times the MDP and **minimum**
29 number of 100 cycles. When the shut-off valve does not incorporate a handwheel, the forces and torques
30 used in the endurance test shall be representative of those used in service to open and close the valve
31 member. Prior to and following the endurance test, a shut-off valve shall be tested for leakage from an
32 internal and external leakage perspective at a test pressure of 1,5 times MDP at minimum and maximum
33 service temperature. Leakage rates less than or equal to 3 standard cm^3/h (standard conditions of 0 °C
34 and 101.325 kPa absolute) shall be acceptable.
- 35 The minimum rated pressure of the shut-off valve shall be at least equal to the MDP.
- 36 In addition, the shut-off valve manufacturer shall demonstrate that the shut-off valve is subjected to the
37 requirements of ISO 14246.

1 **5.7.4 Integral shut-off valve protection**

2 A MH assembly design that uses an integral method of shut-off valve protection that is not meant to be
3 removed for MH assembly operation, such as the use of a shroud, collar or recessing the valve in the MH
4 assembly, shall meet the requirements of the drop test in 6.2.4.

5 **5.7.5 Removable shut-off valve protection**

6 MH assembly designs that use a removable means of shut-off valve protection that is meant to be removed
7 for MH assembly operation, such as a cover, cap or guard, shall meet the requirements of the drop test in
8 6.2.4 with the protective means in place and meet the requirements of the shut-off valve impact test in 6.2.7
9 without the protective means in place.

10 Removable means of shut-off valve protection, having passed the drop test in 6.2.4, shall be acceptable for
11 use only with filled MH assemblies at a mass equal to or less than the mass tested and with MH assemblies
12 with shut-off valves of dimensions not exceeding those of the tested shut-off valve.

13 **5.8 Actively cooled MH assemblies**

14 MH assemblies that employ an active cooling system to control and/or affect system temperature shall be
15 designed to ensure that there will be no inadvertent leakage of fluid between the MH assembly and the
16 cooling system. The cooling system shall be employed when performing the hydrogen cycling and strain
17 measurement test in 6.2.6.

18 **NOTE** Some coolants can react with hydrides. If such coolant is used it shall be properly addressed in the
19 risk assessment.

20 **5.9 Particulate containment**

21 Particulate matter shall not impede the functioning of the valves or PRDs. A means of particulate matter
22 containment may be used to achieve this purpose. The MH assemblies shall meet the requirements of the fire
23 test of 6.2.2 and the hydrogen cycling and strain measurement test of 6.2.6.

24 **6 Inspection and testing**

25 **6.1 General**

26 Evaluation of conformity shall be performed in accordance with the relevant regulations of the country where
27 the MH assemblies are used.

28 In order to ensure that the MH assemblies are in compliance with this International Standard, they shall be
29 subject to inspection and testing in accordance with this clause. Inspection and testing shall be performed by
30 an authorized inspection body recognized in the countries of use.

31 **NOTE** Some countries do not require inspection and testing to be carried out by an authorized inspection body.

32 **6.2 Type/qualification tests**

33 **6.2.1 General**

34 The following type tests shall be performed to qualify an MH assembly design. The MH assemblies used for
35 the type tests shall be representative of production MH assemblies. The data for all type tests shall be
36 acquired using calibrated instruments.

1 Any change in shell design, hydrogen absorbing alloy, manufacturing process or loading procedure of
2 hydrogen absorbing alloy shall require repeating the fire test of 6.2.2, the drop test of 6.2.4 and the hydrogen
3 cycling and strain measurement test of 6.2.6, and, if applicable, the thermal cycling test of 6.2.8.

4 Compliance to this International Standard shall be recorded for each MH assembly design on a type approval
5 certificate. An example of a suitably worded certificate is given in Annex C.

6 **6.2.2 Fire test**

7 **6.2.2.1 General**

8 The fire test shall be performed on all new MH assembly designs to demonstrate that the fire protection
9 system, such as PRD and/or integral thermal insulation, will prevent the rupture of the MH assembly under the
10 specified fire conditions.

11 Any significant change to the design as defined in the standard (see 5.3) to which the shell is designed
12 (including, but not limited to, changes in diameter, length, shell material type and minimum design thickness)
13 and any change to the type, number or flow capacity of the PRD, means of solid particulate containment or in
14 the hydrogen absorbing alloy shall necessitate repeating the fire test.

15 As an exception, a manufacturer may use data and engineering calculations, based on previous fire test
16 results on existing designs, in cases involving design changes that would reduce the risk of shell failure in the
17 fire test (e.g. reduction in shell length, or increase in PRD flow capacity), to show that a new design does not
18 require repeating the fire test.

19 Precautions should be taken to ensure safety of personnel and property during the fire test in the event that an
20 MH assembly rupture occurs.

21 **6.2.2.2 Sample preparation**

22 The MH assembly shall be filled to rated capacity with hydrogen.

23 **6.2.2.3 Data monitoring and recording**

24 The temperature and pressure of the MH assembly shall be monitored remotely and recorded at intervals of
25 15 μ s. A valve shall be installed to allow venting of the MH assembly in the event of a malfunction of the test
26 equipment or system.

27 In addition to the temperature and pressure readings, the following information shall also be recorded for each
28 test:

29 — MH assembly manufacturer;

30 — MH assembly part or model number;

31 — unique identifier;

32 — PRD-type and rating;

33 — PRD location and orientation;

34 — date of test;

35 — MH assembly RCP;

36 — number of charge/discharge cycles that the MH assembly has undergone;

- 1 — MH assembly orientation (vertical, horizontal or inverted);
- 2 — ambient temperature;
- 3 — estimated wind condition/direction;
- 4 — names of witnesses;
- 5 — time of activation of PRD; and
- 6 — elapsed time to completion of the test.

7 For MH assembly designs that contain small quantities of hydrogen that preclude accurate monitoring of
8 pressure during the fire test, a statement of justification for not monitoring the pressure during the fire test
9 shall be provided, along with a description of the means for determining activation of the PRD.

10 **6.2.2.4 Test set-up, fire source and test method**

11 The fire tests shall be conducted on at least three MH assemblies in each orientation of intended use and/or
12 transportation. For MH assembly designs for which the orientation of use and transportation are not specified,
13 at least three MH assemblies shall be fire tested in each of the vertical and horizontal orientation and any
14 other orientation due to asymmetry of the MH assembly design, if applicable. The tests shall include at least
15 one test with the PRD oriented towards the fire source and at least one test with the PRD oriented 180° away
16 from the fire source.

17 The MH assemblies, over their entire width, shall be subjected to a fire source of a maximum length of 1.65 m.
18 For MH assemblies less than 1.65 m in length, the fire source shall totally engulf the MH assembly. MH
19 assemblies longer than 1.65 m or equipped with multiple PRDs with a spacing greater than 1.65 m, shall be
20 subjected to a partial engulfment fire test in the horizontal orientation. If an MH assembly is longer than 1.65 m
21 and is fitted with a PRD at one end, the opposite end of the MH assembly shall be subjected to the fire source.
22 If the MH assembly is fitted with PRDs at both ends, or at more than one location along the length of the MH
23 assembly, the fire source shall be centred midway between the PRDs that are separated by the greatest
24 horizontal distance.

25 For MH assemblies less than or equal to 0.30 m in length, a temperature-indicating device shall be installed
26 within 0.05 m of, but not in contact with, the MH assembly surface near each end. For MH assemblies greater
27 than 0.30 m in length, a temperature-indicating device shall be installed at each end and one at the midpoint.
28 Temperature-indicating devices may be inserted into small metallic blocks (less than 0.025 m per side).

29 MH assemblies shall be subjected to a direct flame impingement test. Sufficient fuel shall be supplied to
30 ensure a burn time of at least 20 min. The MH assembly shall be placed in the test orientation with the MH
31 assembly at least 0,1 m above the fuel or at a greater height to ensure total flame engulfment. The fire shall
32 produce a flame that totally engulfs the MH assembly. Shielding shall be used to prevent direct flame
33 impingement on the shut-off valve, fittings, and/or PRD(s). The shielding shall not be in direct contact with the
34 specified fire protection system.

35 Any fuel may be used for the fire source, provided it supplies uniform heat sufficient to maintain the specified
36 test conditions for a minimum of 20 min. The fire test should to be carried out in a properly ventilated facility or
37 in open ground for safety. The selection of a fuel should take into consideration air pollution concerns. The
38 arrangement of the fire shall be recorded in detail to ensure that the rate of heat input to the MH assembly is
39 reproducible.

40 NOTE MH assemblies that have been subjected to the cycling and strain measurement test of 6.2.6 may be used in
41 this test.

1 6.2.2.5 Acceptance criteria

2 Any failure or inconsistency of the fire source during a test shall invalidate the result, and a re-test shall be
3 carried out. Any venting through, or rupture of, the shell, valve, fitting or tubing during the test that is not part
4 of the intended protection system, shall invalidate the result and a re-test shall be carried out.

5 The MH assembly design shall be deemed to have passed the fire test if, for all valid tests, there is no
6 generation of projectiles and one of the following criteria is met:

7 — the PRD or other venting method of all MH assemblies subjected to the fire test vent each MH assembly
8 to zero gauge pressure without rupture of the MH assembly; or

9 — all MH assemblies subjected to the fire test withstand the fire for a minimum of 20 min without rupture.

10 6.2.3 Initial burst tests for MH assemblies with an internal volume of 120 ml or less

11 At least three MH assemblies shall be subjected to an initial burst test to demonstrate compliance to 5.3.2 b).
12 Either a hydrostatic or a pneumatic burst test shall be performed; however, all tests shall be performed in the
13 same manner. All bursts shall occur in the same manner for all tests performed.

14 Adequate precautions should be taken to ensure safety of equipment and personnel. In particular, during a
15 pneumatic burst testing, personnel should be aware of the potential for releases of large amounts of stored
16 energy and potentially hazardous materials as a result of the burst.

17 6.2.4 Drop or impact test

18 6.2.4.1 General requirements

19 6.2.4.1.1 MH assembly with mass of 25kg or less

20 All MH assembly with mass lower than 25kg designs shall meet the requirements of the drop test. Any
21 significant change to the design as defined in the standard (see 5.3) to which the shell is designed (including,
22 but not limited to, changes in diameter, length, shell material type and minimum design thickness) and any
23 change in shut-off valve, means of solid particulate containment or loaded mass of the hydrogen absorbing
24 alloy shall necessitate repeating the drop test.

25 The surface onto which the MH assemblies are dropped shall be a smooth, horizontal, concrete or steel
26 surface. The container shall be allowed to bounce on the concrete or steel surface after the initial impact. No
27 attempt shall be made to prevent this secondary impact. A guide rail for posture maintenance may be used,
28 provided that it does not reduce the free-fall velocity.

29 6.2.4.1.2 MH assembly with mass greater than 25 kg

30 All MH assembly with mass higher than 25kg designs shall meet the requirement of the blunt impact test. Any
31 significant change to the design as defined in the standard (see 5.3) to which the shell is designed (including,
32 but not limited to, changes in diameter, length, shell material type and minimum design thickness) and any
33 change in shut-off valve, means of solid particulate containment or loaded mass of the hydrogen absorbing
34 alloy shall necessitate repeating blunt test

35 6.2.4.2 Sample preparation MH assembly with mass of 25kg or less

36 The MH assemblies used for these tests shall include their integral or removable shut-off valve protection (see
37 5.7.4 and 5.7.5). The MH assemblies shall have an equivalent weight ($\pm 2\%$), packing density and internal
38 structure as production MH assemblies. Ballast material may be used in place of the hydrogen absorbing alloy.
39 The MH assemblies shall not be pressurized.

6.2.4.3 Drop Test procedure

MH assemblies shall be drop tested in accordance with the following conditions. One MH assembly may be used for all drop tests performed in a) to c). The drop tests shall be carried out at room temperature (20^{+10}_{-5}) °C.

a) One MH assembly shall be dropped vertically on the end containing the shut-off valve assembly. One MH assembly shall be dropped vertically on the end opposite the shut-off valve assembly. In both cases, the MH assembly shall be dropped from a height of not less than 1,8 m measured from the lower end of the MH assembly.

b) One MH assembly shall be dropped at a 45° angle on the end containing the shut-off valve assembly from a height such that the centre of gravity is at a minimum height of 1,8 m. If the lower end of the MH assembly is at a height of less than 0,6 m, the drop angle shall be changed to maintain the lower end of the MH assembly and the centre of gravity at a minimum height of 0,6 m and 1,8 m respectively. When the shut-off valve, PRD and other appurtenances are set on both ends of the MH assembly, the MH assembly shall be dropped at a 45° angle on its weakest end.

c) One MH assembly shall be dropped horizontally from a height of 1,8 m onto a steel apex as shown in Figure 1. The MH assembly shall be placed such that its centre of gravity is aligned with the rounded edge of the steel apex as shown in Figure 1. In order to prevent movement of the steel apex by the collision of the MH assembly, the steel apex shall be fixed to the concrete pad or flooring. The MH assembly shall strike the steel apex before striking the concrete pad or flooring.

d) For shells of composite design (such as shells designed according to ISO 11119-1, ISO 11119-2 or ISO 11119-3) at least one additional MH assembly shall be dropped according to a) and b).

Dimensions in millimetres

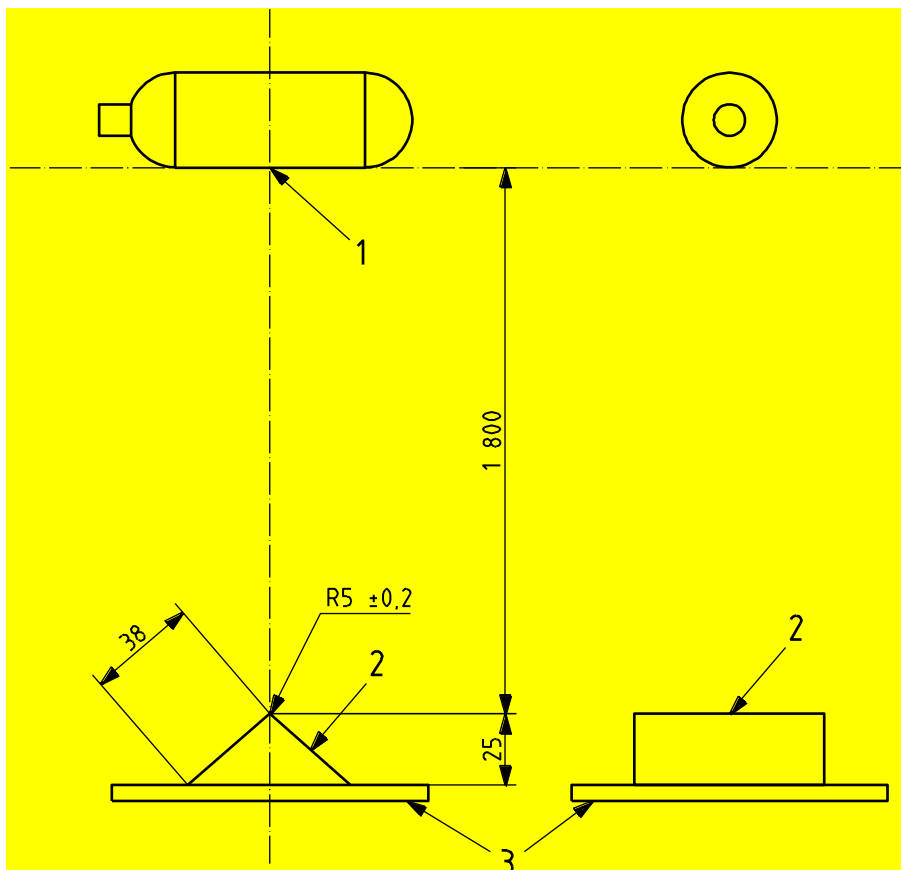

- 1 **Key**
 2 1 centre of gravity
 3 2 steel apex
 4 3 smooth, horizontal concrete pad or flooring

5 **Figure 1 — MH assembly drop test onto an apex**

6 **6.2.4.4 Acceptance criteria for MH assembly with mass of 25kg or less**

7 **6.2.4.4.1 General**

8 The shut-off valve shall remain operational (i.e. capable of being opened and closed) after all drop tests.

9 All MH assemblies that have undergone the drop tests shall be visually inspected and all apparent damage
 10 recorded. All MH assemblies shall be subjected to the leak test of 6.2.5 at a temperature of (20_{-5}^{+10}) °C and
 11 MDP and meet the acceptance criteria.

12 MH assemblies dropped in accordance to 6.2.4.3 d), shall additionally be subjected to the ambient cycle test
 13 of ISO 11119-2, 8.5.5, and withstand 3 000 pressurization cycles at five-sixths of the MDP without failure by
 14 burst or leakage.

15 After successful completion of the leak test and, if applicable, the ambient cycle test specified above, all MH
 16 assemblies shall be pressurized to destruction as per 6.2.4.4.2 or 6.2.4.4.3 and meet the acceptance criteria.

17 **6.2.4.4.2 MH assemblies with internal volume greater than 120 ml**

18 The MH assemblies shall be pressurized to destruction using a hydrostatic burst test. The recorded burst
 19 pressures shall exceed 85 % of the minimum shell burst pressure specified by the standard to which the shell
 20 was designed. All bursts shall occur in a manner consistent with the standard to which the shell was designed
 21 and in the same manner for all tests performed.

22 **6.2.4.4.3 MH assemblies with internal volume of 120 ml or less**

23 The MH assemblies shall be pressurized to destruction using a hydrostatic or a pneumatic burst test. The
 24 recorded burst pressures shall exceed 85 % of the minimum shell burst pressure specified in 5.3.2. All bursts
 25 shall occur in a manner consistent with the initial burst test of 6.2.3 and in the same manner for all tests
 26 performed.

27 Adequate precautions should be taken to ensure safety of equipment and personnel. In particular, during a
 28 pneumatic burst testing, personnel should be aware of the potential for releases of large amounts of stored
 29 energy and potentially hazardous materials as a result of the burst.

30 **6.2.4.5 Blunt impact test for MH Assembly with mass greater than 25kg**

31 The MH assembly designed and tested according to ISO 7866, ISO 9809-1, ISO 9809-3, ISO 11119-1,
 32 ISO 11119-2, ISO 11119-3 having mass higher than 25kg shall be subjected to blunt impact testing in
 33 accordance with 6.2.4.6.

34 The MH assembly designed with proof of performance in accordance to ISO16528 shall be tested in
 35 accordance to the procedure of Type 1 and Type 2 following procedure described in 6.2.4.6 the blunt impact
 36 test must be performed at the lowest shell thickness location.

37 **6.2.4.6 Blunt Impact Test Procedure**

38 For Type 1 and Type 2 MH assembly, one empty shell shall be subjected to two impacts:

- 39 a) at the MH assembly sidewall midway between the ends;

- 1 b) at the termination of the overwrap near the domes for Type 2.
- 2 For Type 3 and 4 MH assembly, one empty shell shall be subjected to two impacts in each of the following
- 3 positions:
- 4 a) at the MH assembly sidewall midway between the ends;
- 5 b) at an angle of 45° to strike the shoulder of the tube (mid arc length at the dome).
- 6 The impact can be conducted by dropping a suitable weight or by a pendulum impact.
- 7 The MH Assembly shall be secured to ensure it does not move during the impact. The impactor shall be made
- 8 from steel bar and have a diameter of between 70 and 80 mm and strike the tube with an energy of
- 9 1 200 joules.
- 10 The MH Assembly shall then be subjected to the appropriate ambient cycle test as described in ISO 11515:
- 11 8.5.5.. In this case the application to this standard will be extended to volume lower than 150l.
- 12 Parameters to monitor and record are:
- 13 a) visual appearance after each impact - record position and dimensions of impact damage;
- 14 b) parameters specified in test in ISO 11515: 8.5.5

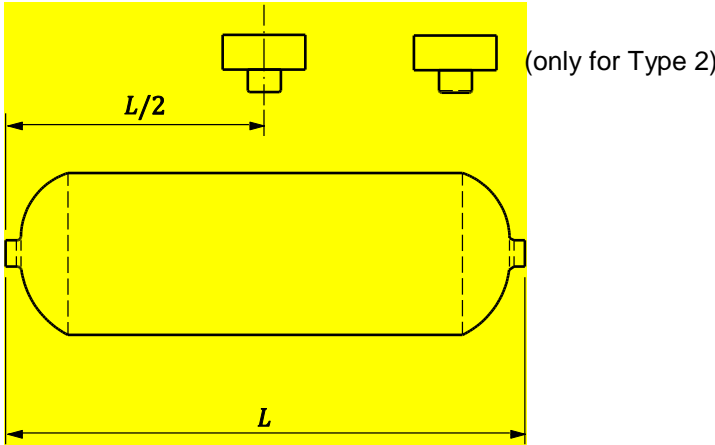

15
16 a) Type 1 & Type 2 Tubes

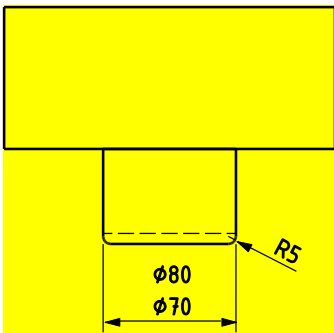

17
18 b) Example of impactor

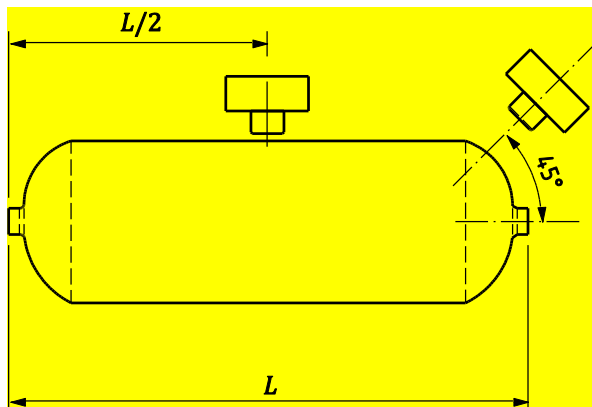

c) Type 3 & Type 4 tubes
Figure 2 — Blunt Impact test procedure

6.2.4.7 Acceptance Criteria for MH assemblies with mass greater than 25 kg

The shell shall withstand N/4 pressurisation cycles at MDP without failure by burst or leakage. The test shall continue for a further N cycles, or until the shell fails by leakage, whichever is the sooner. In either case the MH Assembly shall be deemed to have passed the test. However if failure during this second part of the test is by burst, then the MH Assembly shall have failed the test. N is the number of cycles required in the shell standards for example (12000 cycles for ISO7866)

6.2.5 Leak test

6.2.5.1 Test procedure

The MH assembly shall be charged with hydrogen, helium, or a blend of the two, and monitored for leaks at the conditions indicated in Table 1.

Table 1 — Temperature/pressure conditions for leak test

Temperature	Pressure
Minimum service temperature	RCP
$(20^{+10}_{-5})\text{ }^{\circ}\text{C}$	RCP
Highest temperature between maximum service temperature or maximum operating temperature	MDP

NOTE Before placing the MH assembly in an enclosed area to perform the leak test of either 6.2.5.2.1 or 6.2.5.2.2, it is recommended to test for the presence of major leaks using a soap bubble solution, or by other adequate means, on all possible leak locations.

6.2.5.2 Acceptance criteria

6.2.5.2.1 MH assemblies with internal volume greater than 120 ml

The total hydrogen leak rate shall be less than K standard cm^3/h (standard conditions of $0\text{ }^{\circ}\text{C}$ and 101,325 kPa absolute). If hydrogen gas is not used, the leak rate shall be converted into an equivalent hydrogen leak rate.

The value of K is defined by the following equation: K should be the greater value of : 6 or $15 \times (\text{internal volume of the shell in litres}/150)$

6.2.5.2.2 MH assemblies with internal volume of 120 ml or less

The total hydrogen leak rate shall be less than 3 standard cm³/h (standard conditions of 0 °C and 101,325 kPa absolute). If hydrogen gas is not used, the leak rate shall be converted into an equivalent hydrogen leak rate.

6.2.6 Hydrogen cycling and strain measurement test**6.2.6.1 General**

The hydrogen cycling and strain measurement test shall be performed on all new MH assembly designs to demonstrate that the design stress limits of the shell are not exceeded during use. Any significant change to the design as defined in the standard (see 5.3.1) to which the shell is designed (including, but not limited to, changes in diameter, length, shell material type and minimum design thickness) and means of solid particulate containment or formulation of or loaded mass of the hydrogen absorbing alloy shall necessitate repeating the hydrogen cycling and strain measurement test. MH assemblies that employ an active cooling system to control and/or affect system temperature shall be subjected to the test with the cooling system in place.

Precautions should be taken to ensure safety of personnel and property during testing in the event that an MH assembly failure or hydrogen release occurs.

6.2.6.2 Test set-up

Each MH assembly shall be adequately instrumented, for instance with strain gauges, to determine the maximum local strain that the shell experiences during cycling. With MH assemblies, the strain may not be uniform throughout the MH assembly. The number and location of the strain gauges required to measure the highest strain experienced by the shell may be determined from engineering models based on knowledge of the design, including stress distribution and analysis information provided by the shell manufacturer, the internal configuration and geometry, hydrogen absorbing alloy distribution, etc. If engineering models cannot accurately determine the points of expected highest strain, the number and locations of required strain gauges shall be empirically determined by extensively instrumenting at least two MH assemblies with strain gauges and performing the test. Based on the results, further testing may be performed using fewer strain gauges that are strategically placed to measure the highest strain levels experienced by the shell.

As a minimum, the hoop strain shall be monitored on cylindrical and dome sections of MH assemblies, bending strain shall be monitored on flat sections of MH assemblies and for strain concentration points (such as corners and edges), the strain in areas around the concentration point shall be monitored, and a concentration factor shall be used to estimate the strain at the concentration point.

The strain gauges shall be protected from damage during extended testing and exposure to the cycling environment, for example by the use of a chemically-resistant epoxy. Periodically during and, at least, at the start and end of cycling, the strain gauges shall be calibrated to ensure proper functioning. If any strain gauge is found to not be properly functioning, it shall be replaced.

The strain at the design stress limit shall be determined either by engineering calculations based on the shell design and material properties, or empirically by internally applying either a pneumatic or hydrostatic pressure up to a pressure equivalent to the shell design stress limit and measuring the strain. For any MH assembly where the strain gauges are applied to an outer layer and not directly to the shell or liner in contact with the metal hydride and hydrogen gas (such as shells of type II and III fibre-wrapped composite cylinder design) or for any shell that has been intentionally subjected to plastic deformation (i.e. autofrettage), the strain at the design stress limit for each gauge shall be determined empirically prior to cycling the MH assemblies with hydrogen.

6.2.6.3 Test method

For MH assemblies designed to be transported and used in a single orientation, at least five MH assemblies shall be tested in that orientation. For MH assembly designs that do not preclude use in more than one orientation, at least three MH assemblies shall be tested in two orientations perpendicular to each other, with

1 the MH assembly axis horizontal and vertical. The MH assemblies shall be hydrogen charge cycled from not
 2 more than 5 % of rated capacity to not less than 95 % of rated capacity. The RCP shall be used for charging
 3 and the temperatures shall be held within the operating temperature range. The cycling shall be continued for
 4 at least 106 cycles and until the acceptable results defined in 6.2.6.4 but never beyond the maximum cycling
 5 number provided by the manufacturer. If the measured strain on consecutive cycles exceeds the design stress
 6 limit or plastic deformation of the shell material occurs, the testing shall be discontinued.

7 As a minimum, a measurement from each strain gauge shall be recorded on every cycle while at the
 8 maximum charge condition.

9 For MH assembly with internal volume of 120ml or less additional vibration cycle must be performed. Vibration
 10 cycle after the fifth complete cycle and then at intervals of not more than 50 cycles, with the MH assemblies
 11 charged to not more than 5 % of their rated capacity, each MH assembly shall be subjected to the following
 12 vibrational sequence while in the orientation for cycling:

13 — A sinusoidal waveform with a logarithmic sweep between 7 Hz and 200 Hz and back to 7 Hz traversed in
 14 15 min. This cycle shall be repeated 12 times for a total of 3 h for each MH assembly. The logarithmic
 15 frequency sweep shall be as follows: from 7 Hz a peak acceleration of $1 g_n$ shall be maintained until
 16 18 Hz is reached. The amplitude shall then be maintained at 0,8 mm (1,6 mm total excursion) and the
 17 frequency increased until a peak acceleration of $8 g_n$ occurs (approximately at 50 Hz). A peak
 18 acceleration of $8 g_n$ shall then be maintained until the frequency is increased to 200 Hz.

19 Figure 3 shows the minimum cycling requirements for MH assembly with internal volume of 120ml or less.

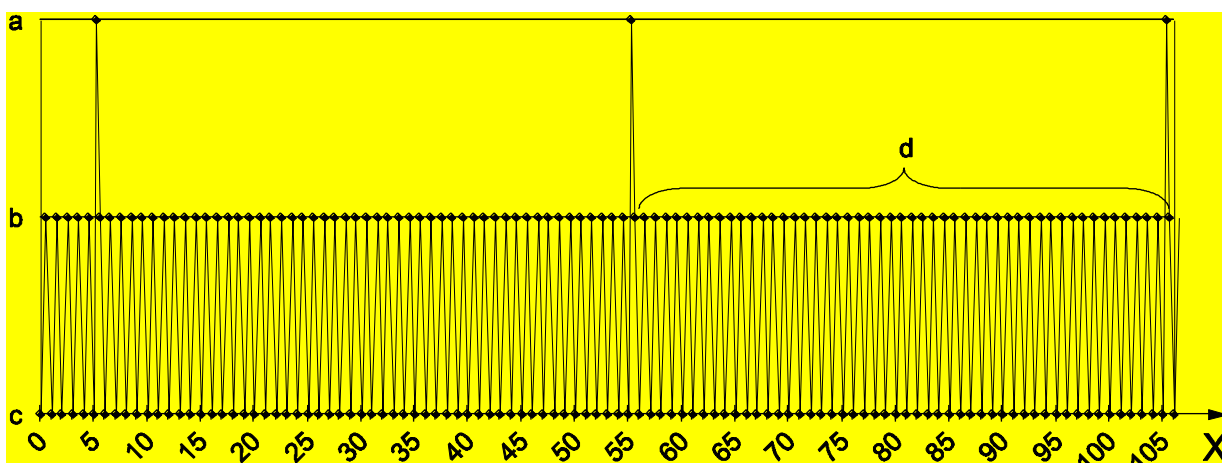

20

21 Key

22 X cycle number

23 Linear regression analysis shall show no increase in strain for the last 50 consecutive cycles (d); the cycling
 24 pattern is continued until this condition is met.

25 a vibrate

26 b charge

27 c discharge

28 d last 50 consecutive cycles

29 **Figure 3 — Graphical depiction of minimum cycle requirements with internal volume of 120ml or less**

30 6.2.6.4 Acceptance criteria

31 For each strain gauge in a period of 50 consecutive cycles, either the maximum measured strain shall not be
 32 greater than 50 % of the strain at the design stress limit, or, there is no trend of increasing strain. The MH

1 assembly shall be considered to have failed the test and a redesign shall be required if, for any strain gauge,
 2 the strain for consecutive cycles exceeds the strain for the shell at the design stress limit or if the shell
 3 experiences plastic deformation.

4 To determine that there is no trend of increase in strain, the data for each strain gauge with a maximum strain
 5 greater than 50 % of the strain at the design stress limit shall be analysed by the least squares linear
 6 regression method, according to the equation:

$$7 \quad a = \frac{\left(\sum_{i=j}^{j+N} y_i x_i \right) - N \bar{y} \bar{x}}{\left(\sum_{i=j}^{j+N} x_i^2 \right) - N \bar{x}^2}$$

8 where

9 a is the coefficient indicating the slope of the measured strain data;

10 x is the cycle number;

$$11 \quad \bar{x} = \frac{1}{N} \sum_{i=j}^{j+N} x_i \quad (\text{average cycle number});$$

12 N shall be 50, the number of consecutive cycles analysed;

13 y the measured strain; and

$$14 \quad \bar{y} = \frac{1}{N} \sum_{i=j}^{j+N} y_i \quad (\text{the average strain}).$$

15 The MH assembly shall be cycled until, for a period of 50 consecutive cycles, the coefficient a is less than or
 16 equal to zero for all strain gauges that have a strain reading greater than 50 % of the strain at the design
 17 stress limit. The 50 cycles analysed shall be the final 50 consecutive cycles performed. This criterion shall be
 18 met by all strain gauges on an MH assembly for the same period of consecutive cycles.

19 Additionally, after completion of the cycling and strain measurement test, all MH assemblies shall be
 20 pressurized, and with a blank-off on the outlet, the valve shall be cycled between the open and closed
 21 positions a minimum of two times. With the blank-off removed from the outlet, all MH assemblies shall meet
 22 the acceptance criteria of the leak test of 6.2.5. At least one MH assembly from each orientation tested shall
 23 be subjected to the fire test of 6.2.2 and meet the acceptance criteria.

24 Adequate precautions should be taken to ensure safety of equipment and personnel. In particular, during
 25 pneumatic burst testing, personnel should be aware of the potential for releases of large amounts of stored
 26 energy and potentially hazardous materials as a result of the burst.

27 For MH assemblies that employ an active cooling system to control and/or affect system temperature, any
 28 inadvertent leakage between the MH assembly and cooling fluid shall be considered a failure to meet the
 29 acceptance criteria of this test.

1 **6.2.7 Shut-off valve impact test**

2 **6.2.7.1 General**

3 As indicated in 5.7.5, MH assembly designs that employ a removable means of valve protection shall be
4 subjected to the following shut-off valve impact test.

5 **6.2.7.2 Sample preparation**

6 Three MH assemblies shall be subjected to this shut-off valve impact test. For the purpose of this test, ballast
7 may be used in place of the hydrogen absorbing alloy or the shell may be left empty. The MH assemblies shall
8 not be pressurized with gas during the test. The removable shut-off valve protection shall be removed for this
9 test.

10 **6.2.7.3 Test procedure**

11 A hardened steel ball or an impact object tipped with a hardened steel ball shall be used for this test. The
12 hardened steel ball shall have a Brinell hardness of 248 ± 3 and its diameter shall be allowed to vary with
13 respect to the size of the shut-off valve to allow it to strike the side of the valve 90° to the longitudinal axis of
14 the valve and co-incident with a plane passing through the same axis.

15 The hardened steel ball, or the impact object tipped with a hardened steel ball, as well as the MH assembly,
16 shall be conditioned for at least 4 h at -40°C . Within 5 min after conditioning, the MH assembly shall be
17 rigidly anchored and the shut-off valve shall be subjected to the following two impacts. The first impact shall
18 strike the side of the shut-off valve 90° to the longitudinal axis of the valve and co-incident with a plane
19 passing through the same axis. The points of impact on the shut-off valve shall not be obstructed by features
20 such as outlet connecting threads, pressure relief devices, handwheel, etc. The hardened steel ball or the
21 impact with a hardened steel ball object shall have sufficient mass and velocity to impart the minimum energy
22 specified in Table 2. After the first impact, the MH assembly shall be rotated 180° and a second side impact
23 test shall be conducted on the other side of the shut-off valve.

24

Table 2 — Ball impact requirements for valves

MH assembly type (V = internal volume in litres)	Minimum energy (E) ^a joules
$V < 0.35$	1.02
$0.35 < V < 10$	6.80
$10 < V < 25$	13.50
$25 < V < 100$	27.10
$100 < V$	162.70

^a For example, for a free falling impact object tipped with a hardened steel ball,

$$E = mg_ch$$
where
 E is energy, expressed in joules (J);
 m is mass of the impact object tipped with a hardened steel ball, expressed in kilograms (kg);
 g_c is the acceleration due to gravity ($9,8 \text{ m/s}^2$);
 h is the vertical drop height, expressed in metres (m).

1 6.2.7.4 Acceptance criteria

2 Following the two impacts tests, each shut-off valve and MH assembly shall be visually inspected for damage
3 and subjected to the leak test of 6.2.5 at (20_{-5}^{+10}) °C and MDP and meet the requirements therein.

4 The shut-off valve connection (inlet threads) shall remain intact without cracking and the shut-off valve shall
5 be operative. A break of the handwheel shall not be considered as a failure to meet the test requirements as
6 long as the shut-off valve is still capable of being opened and closed.

7 If the requirements of the leak test are not met or the shut-off valve does not remain operational after the tests,
8 the test shall be repeated on three MH assemblies fitted with their removable shut-off valve protection. If the
9 three MH assemblies meet the acceptance criteria, the design shall be considered as acceptable, provided
10 each MH assembly is marked in accordance with 7.2.3.

11 6.2.8 Thermal cycling test

12 6.2.8.1 General

13 The thermal cycling test shall be performed on MH assemblies with an internal volume of 120 ml or less only.

14 NOTE This test is being performed to address potential concerns regarding not having performed a pressure cycling
15 test similar to that prescribed in the ISO cylinder standards. This test is intended to thermally cycle a complete MH
16 assembly over its service temperature range.

17 6.2.8.2 Test set-up

18 For MH assemblies designed to be transported and used in a single orientation, at least five MH assemblies
19 shall be tested in that orientation. For MH assembly designs that do not preclude use in more than one
20 orientation, at least three MH assemblies shall be tested in two orientations perpendicular to each other, with
21 the MH assembly axis horizontal and vertical.

22 The MH assembly shall be filled to rated capacity with hydrogen. The MH assembly shall be placed in a
23 temperature-controlled test chamber capable of cycling from minimum service temperature to maximum
24 service temperature and vice versa over a period of 2 h.

25 6.2.8.3 Test procedure

26 The MH assemblies shall be subjected to the following thermal cycles (see Figure 3).

- 27 a) Place the MH assembly in the temperature-controlled test chamber and increase the chamber temperature
28 from (20_{-5}^{+10}) °C to the maximum service temperature with a tolerance of ± 5 °C in $1 \text{ h} \pm 5 \text{ min}$.
- 29 b) Keep the MH assembly at the maximum service temperature with a tolerance of ± 5 °C for a minimum of
30 1 h.
- 31 c) Decrease the chamber temperature to (20_{-5}^{+10}) °C in $1 \text{ h} \pm 5 \text{ min}$, then decrease the chamber
32 temperature to the minimum service temperature with a tolerance of ± 5 °C in $1 \text{ h} \pm 5 \text{ min}$.
- 33 d) Hold the chamber temperature at the minimum service temperature with a tolerance of ± 5 °C for a
34 minimum of 1 h.
- 35 e) Increase the chamber temperature to (20_{-5}^{+10}) °C in $1 \text{ h} \pm 5 \text{ min}$.
- 36 f) Repeat steps a) to e) 50 times.

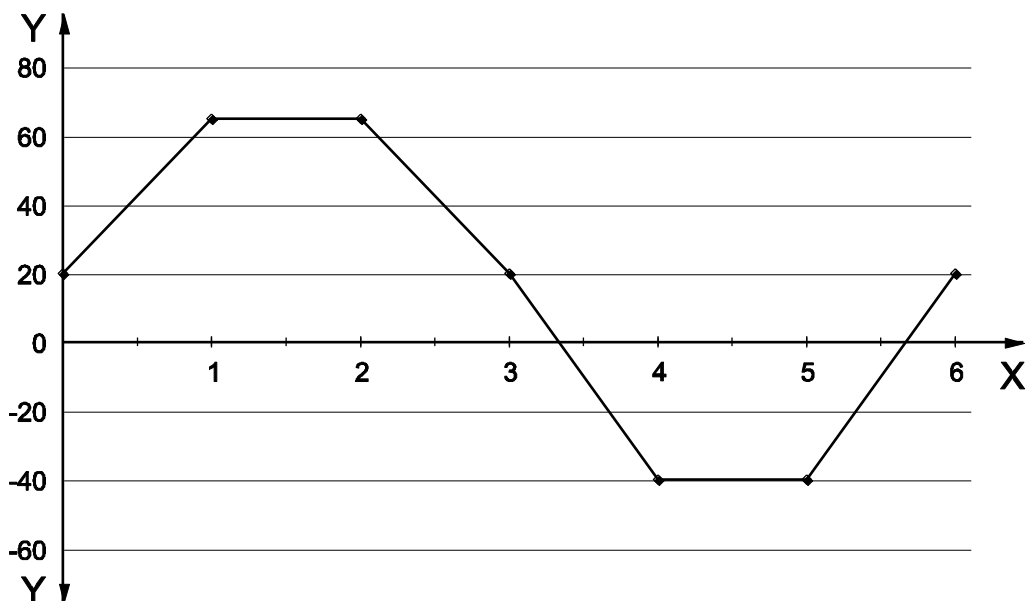

1

2 **Key**

3 X time (h)

4 Y temperature (°C)

5

Figure 2 — Temperature cycling test example cycle

6 **6.2.8.4 Acceptance criteria**

7 Each MH assembly shall be subjected to, and meet the acceptance criteria of, the leak test of 6.2.5 following
8 the thermal cycling test.

9 After completion of the leak testing, at least one MH assembly from each orientation tested shall be
10 pressurized to destruction. The burst test may be either a hydrostatic or a pneumatic burst test. The recorded
11 burst pressures shall exceed the minimum shell burst pressure specified in 5.3.2. All bursts shall occur in a
12 manner consistent with the initial burst test specified in 6.2.3 and in the same manner for all tests performed.

13 Adequate precautions should be taken to ensure safety of equipment and personnel. In particular, during
14 pneumatic burst testing, personnel should be aware of the potential for releases of large amounts of stored
15 energy and potentially hazardous materials as a result of the burst.

16 **6.2.9 Type test reports**

17 The type test reports verifying compliance with the requirements of this International Standard shall be made
18 available to users upon request.

19 **6.3 Batch tests**20 **6.3.1 General requirements**

21 Batch testing shall be conducted at specified intervals during manufacturing to ensure consistency of the
22 manufactured MH assemblies with the prototype design.

23 The size of a batch shall be determined by the manufacturer with consideration to the volume of MH assembly
24 and the material of construction. Two type of batch size can be considered:

25 a) The hydride-batch size consists of one lot of hydrogen absorbing alloy or as approved by the
26 competent authority

- 1 b) The shell-batch size consists of the batch size of the shell as defined in the shell standard, or as
2 approved by the competent authority.

3 All batch tests of the MH assembly shall be carried out on finished MH assemblies.

4 **6.3.2 Burst test for shell-batch**

5 At least one shell from each batch shall be pressurized to destruction.

6 For MH assemblies with internal volume greater than 120 ml, the burst tests methods and acceptance criteria
7 shall meet the requirements of the standard (see 5.3.1) to which the shell is designed.

8 For MH assemblies with an internal volume of 120 ml or less, the burst tests shall be performed in accordance
9 with 6.2.3. All bursts shall occur in a manner consistent with the initial bursts tests specified in 6.2.3 and in the
10 same manner for all tests performed. Adequate precautions should be taken to ensure safety of equipment
11 and personnel. In particular, during pneumatic burst testing, personnel should be aware of the potential for
12 releases of large amounts of stored energy and potentially hazardous materials as a result of the burst.

13 **6.3.3 MDP Test for Hydride-batch**

14 At least one MH assembly from each hydride-batch shall be tested to verify the MDP according to 4.1.1. In no
15 case the MDP of each batch shall exceed 0.8 times the test pressure of the shell or 25 MPa (250bar).

16 **6.4 Routine tests and inspections**

17 **6.4.1 Routine tests**

18 The manufacturer shall perform routine tests and inspection on each MH assembly and maintain records for
19 not less than 20 years or 1.5 times the service life of the MH assembly, whichever is longer.

20 As part of the routine tests, each completed MH assembly shall be subjected to the leak test of 6.2.5 at
21 (20_{-5}^{+10}) °C and RCP and meet the acceptance criteria.

22 For all shells used in the manufacturing of MH assemblies, the MH assembly manufacturer shall obtain and
23 maintain the documentation verifying that the shell was manufactured, tested and qualified in accordance to
24 the shell standard. The MH assembly manufacturer shall also perform incoming inspection of shells to the
25 degree necessary to ensure that the shells meet the specified requirements.

26 **6.4.2 Certificates of manufacture**

27 A certificate of manufacture shall be prepared for each batch of MH assemblies that meets the requirements
28 of this International Standard in all respects. An example of a suitably worded certificate is given in Annex D.

29 **7 Marking, labelling, and documentation**

30 **7.1 Marking**

31 The MH assembly shall have, as a minimum, the following information permanently marked in a clearly visible
32 location:

- 33 a) a reference to this International Standard;
34 b) the RCP in bar;
35 c) the manufacturer's identification;

- 1 d) the date of manufacturing (month and year);
2 e) a manufacturer's serial or unique identification number; and
3 f) the date of expiry based on the maximum service life (month and year).

4 In cases where, due to size or area limitations, it is not possible to include all of the above information in a
5 legible format, the use of a traceable code may be used. If a traceable code is used, the MH assembly shall
6 still be permanently marked with the RCP, the manufacturer's serial or unique identification number and the
7 date of expiry as per b), e) and f).

8 **7.2 Labelling**

9 **7.2.1 General**

10 The precautionary labelling shall be in accordance with ISO 7225. Labels shall not obscure any permanent
11 shell markings.

12 In cases where, due to size or area limitations, it is not possible to include all information on the label, the
13 information may be included on the packaging or in the documentation distributed with the product, except for
14 a warning that the "contents are flammable", which shall always be included on the product label.

15 NOTE The authority having jurisdiction might require additional labelling such as the appropriate UN identification
16 number and description as defined in the UN Model Regulations on the Transport of Dangerous Goods, part or model
17 number and other cautions and hazard warnings pertinent to the metal hydride MH assembly.

18 **7.2.2 Hazards associated with the solid materials**

19 The manufacturer shall include on the label warnings consistent with the potential hazards of the materials
20 contained within the MH assembly. Consideration should include hazards from reactivity with air, water or
21 other fluids.

22 **7.2.3 Labelling concerning removable valve protection**

23 When required by 6.2.7.4, labelling shall include the following, "WARNING: Valve may be damaged if
24 subjected to impact. KEEP VALVE PROTECTION IN PLACE WHEN NOT CONNECTED FOR USE."

25 **7.2.4 Temperature Warning Labelling**

26 The manufacturer shall include on the label a warning: "DO NOT EXPOSE TO TEMPERATURES ABOVE
27 xx °C, OPEN FLAMES OR IGNITION SOURCES.", where xx shall be no greater than the maximum service or
28 operating temperature whichever is greater.

29 **8 Documentation accompanying the product**

30 **8.1 Material safety data sheets**

31 The material safety data sheets (MSDS) covering both the hydrogen gas and the contained hydrogen
32 absorbing alloy shall be provided for inclusion with all product shipments. The MSDS shall include safety and
33 handling requirements to be followed in case of hydrogen leakage and/or breach of the storage system,
34 exposing the hydrogen absorbing alloy and any potential reactivity with substances such as air, water and
35 cooling fluids, if applicable.

8.2 User's or operating manual

8.2.1 General

A user's or operating manual shall be provided by the manufacturer. The user's or operating manual shall include the minimum service conditions specified in Clause 4, hydrogen quality, initial fill and refill procedures, disposal and recycling information and/or other pertinent limitations on use, including the minimum ventilation for the in-use and storage locations, the minimum periodic testing and inspection procedures, if applicable.

8.2.2 Initial fill and refill procedures

8.2.2.1 Inspection prior to initial filling and refilling

The manufacturer shall specify inspection procedures to be carried out prior to initial filling and prior to refilling of the MH assembly.

Items to be inspected shall include whether the MH assembly is within its service life, labels are legible and secure, components are not damaged or missing in the interface, and that the shell and valve are not damaged, and have not been tampered with or abused.

Criteria shall be provided as to when refilling is allowed or when an MH assembly shall be removed from service.

8.2.2.2 Charging specifications

The manufacturer shall provide the following information, for the initial filling and refilling of the MH assembly:

- safety precautions and potential hazards of which to be aware;
- method for determining when the rated capacity described in 4.2 has been achieved;
- minimum and maximum pressure range (maximum pressure shall not exceed RCP);
- minimum and maximum temperature range;
- other special conditions required for the initial filling and refilling.

8.2.2.3 Equipment

The manufacturer shall specify the requirements for the equipment to be used for initial filling and refilling of MH assemblies to prevent overcharging.

8.2.2.4 Inspections and checks after initial filling and refilling

The manufacturer shall specify an inspection procedure to be carried out after the initial filling and after refilling of the MH assembly. Items to be inspected shall include leakage of hydrogen from the MH assembly and damaged or missing components in the interface (e.g. damaged threads, O-rings or seals).

8.2.2.5 Periodic inspection and testing

The manufacturer shall specify the minimum periodic inspection and testing requirements. These requirements shall be in accordance with the applicable ISO periodic inspection and test standard for the shell (e.g. ISO 6406, ISO 10461 and ISO 11623). In all cases, the periodicity for the periodic inspection and testing shall not exceed 5 years.

Annex A (informative)

Material compatibility for hydrogen service

A.1 Material compatibility for hydrogen service

The components in which gaseous hydrogen or hydrogen-containing fluids are processed, as well as all parts used to seal or interconnect the same, should be sufficiently resistant to the chemical and physical action of hydrogen at the operating conditions.

A.2 Metals and metallic materials

The users of this International Standard should be aware that engineering materials exposed to hydrogen in their service environment may exhibit an increased susceptibility to hydrogen assisted corrosion via different mechanisms such as hydrogen embrittlement and hydrogen attack.

Hydrogen embrittlement is defined as a process resulting in a decrease of the toughness or ductility of a metal due to the permeation of atomic hydrogen.

Hydrogen embrittlement has been recognized classically as being of two types. The first, known as internal hydrogen embrittlement, occurs when the hydrogen enters the metal matrix through material processing techniques and supersaturates the metal with hydrogen. The second type, environmental hydrogen embrittlement, results from hydrogen being absorbed by solid metals coming from the service environment.

The atomic hydrogen dissolved within a metal interacts with the intrinsic defects of the metal typically increasing crack-propagation susceptibility, and thus degrading such basic properties as ductility and fracture toughness. There are both important material and environmental variables that contribute to hydrogen-assisted fractures in metals. The material microstructure is an important consideration as second phases, which may or may not be present due to compositional and processing variations, may affect the resistance of the metal to fracture. Second phases, such as ferrite stringers in austenitic stainless steels, may also have a specific orientation leading to profound anisotropic response in the materials. In general, metals can also be processed to have a wide range of strengths, and the resistance to hydrogen-assisted fracture is known to decrease as the strength of the alloy is increased.

The environmental variables affecting hydrogen-assisted fracture include the pressure of hydrogen, temperature, chemical environment and strain rate. In general, the susceptibility to hydrogen-assisted fracture increases as hydrogen pressure increases. The effect of temperature, however, is not as systematic. Some metals such as austenitic stainless steels exhibit a local maximum in hydrogen-assisted fracture susceptibility as a function of temperature. Although not well understood, trace gases mixed with hydrogen gas can also affect hydrogen-assisted fractures. Moisture, for example, may be detrimental to aluminium alloys since wet oxidation produces high-fugacity hydrogen, while in some steels moisture is believed to improve the resistance to hydrogen-assisted fracture by producing surface films that serve as kinetic barriers to hydrogen uptake. A so-called inverse strain rate effect is generally observed in the presence of hydrogen; in other words, metals are less susceptible to hydrogen-assisted fracture at high strain rates.

At temperatures close to ambient, this phenomenon can affect metals with body centred cubic crystal lattice structure, for example ferritic steels. In the absence of residual stress or external loading, environmental hydrogen embrittlement is manifested in various forms, such as blistering, internal cracking, hydride formation and reduced ductility. With a tensile stress or stress-intensity factor exceeding a specific threshold, the atomic hydrogen interacts with the metal to induce sub-critical crack growth leading to fracture.

1 Hydrogen embrittlement can occur during elevated-temperature thermal treatments, and in service during
2 electroplating, contact with maintenance chemicals, corrosion reactions, cathodic protection, and operating in
3 high-pressure or high temperature hydrogen.

4 Many low-alloyed structural steels may suffer from hydrogen attack at temperatures as low as 200 °C. This is
5 a non-reversible degradation of the steel microstructure caused by a chemical reaction between diffusing
6 hydrogen and the carbide particles in the steel that results in the nucleation, growth and merging of methane
7 bubbles along grain boundaries to form fissures.

8 Hydride embrittlement occurs in metals such as titanium and zirconium and is the process of forming
9 thermodynamically stable and relatively brittle hydride phases within the structure.

10 Clad welding and welds between dissimilar materials often involve high alloy materials. During operation at
11 temperatures over 250 °C, hydrogen diffuses in the fusion line between the high-alloy weld and the
12 unalloyed/low alloy base material. During shutdown, the material temperature drops. The reduced solubility
13 and diffusibility of hydrogen breaks the weld by disbonding.

14 The following are some general recommendations for managing the risk of hydrogen embrittlement.

15 — Select raw materials with a low susceptibility to hydrogen embrittlement by controlling the chemistry (e.g.
16 use of carbide stabilizers), microstructure (e.g. use of austenitic stainless steels), and mechanical
17 properties (e.g. restriction of hardness, preferably below 225 HV, and minimization of residual stresses
18 through heat treatment). Use test methods specified in ISO 11114-4 to select metallic materials resistant
19 to hydrogen embrittlement. The API Publication 941 shows the limitations of various types of steel as a
20 function of hydrogen pressure and temperature. The susceptibility to hydrogen embrittlement of some
21 commonly used metals is summarized in ISO/TR 15916.

22 — Clad welds and welds between dissimilar materials used in hydrogen service should be ultrasonically
23 tested at regular intervals and after uncontrolled shutdowns in which the equipment may have cooled
24 rapidly.

25 — Minimize the level of applied stress and exposure to fatigue situations.

26 — When plating parts, manage the anode/cathode surface area and efficiency, resulting in proper control of
27 applied current densities. High current densities increase hydrogen charging.

28 — Clean the metals using non-cathodic alkaline solutions, and using inhibited acid solutions.

29 — Use abrasive cleaners for materials having a hardness of 40 HRC or above.

30 — Use process control checks, when necessary, to mitigate risk of hydrogen embrittlement during
31 manufacturing.

32 **A.3 Polymers, elastomers and other non-metallic materials**

33 Most polymers can be considered suitable for gaseous hydrogen service. Due account should be given to the
34 fact that hydrogen diffuses through these materials much more easily than through metals.
35 Polytetrafluoroethylene [PTFE or Teflon®¹] and polychlorotrifluoroethylene [PCTFE or Kel-F®²] are generally

1) Teflon® is the trade name of a product supplied by DuPont. This information is given for the convenience of users of this document and does not constitute an endorsement by ISO of the product named. Equivalent products may be used if they can be shown to lead to the same results.

2) Kel-F® is a registered trade name of 3M Company. In 1996, 3M discontinued manufacturing of Kel-F and, today, all PCTFE resin is manufactured by Daikin under the trade name of Neoflon® or by Allied Signal under the trade name of Aclon®. Kel-F is still the most commonly used trade name used to describe PCTFE. This information is given for the convenience of users of this document and does not constitute an endorsement by ISO of the product named. Equivalent products may be used if they can be shown to lead to the same results.

1 suitable for hydrogen service. Suitability of other materials should be verified. Guidance can be found in
2 ISO 11114-2, ISO/TR 15916 and ANSI/AIAA G-095.

3 **A.4 Other references**

4 Further guidance on hydrogen assisted corrosion and control techniques may be found through the following
5 organizations and their standards:

6 **A.4.1 International Organization for Standardization (www.iso.org)**

7 See bibliography [1] to [14].

8 **A.4.2 American Institute of Aeronautics and Astronautics (www.aiaa.org)**

9 See bibliography [15].

10 **A.4.3 American Petroleum Institute (www.api.org)**

11 See bibliography [16] and [17].

12 **A.4.4 American Society for Testing and Materials (www.astm.org)**

13 See bibliography [18] to [32].

14 **A.4.5 American Society of Mechanical Engineers (www.asme.org)**

15 See bibliography [33] to [35].

16 **A.4.6 American Welding Society (www.aws.org)**

17 See bibliography [36].

18 **A.4.7 ASM International (www.asminternational.org) and Society of Automotive Engineers** 19 **(www.sae.org)**

20 See bibliography [37] to [39].

21 **A.4.8 National Association of Corrosion Engineers (www.nace.org)**

22 See bibliography [40] and [41].

23

Annex B (normative)

Environmental tests

B.1 Exposure to fluids

B.1.1 General

This test is applicable to MH assembly shells comprised of Type II, III and IV fibre-wrapped cylinders.

Two shells shall be tested in a condition representative of installed geometry including coating (if applicable), brackets and gaskets, and pressure fittings using the same sealing configuration (i.e. O-rings) as that used in service.

The two shells are subjected to preconditioning in accordance with B.1.2 and then exposed to a sequence of environments, pressures and temperatures in accordance with Table B.1. Although preconditioning and fluid exposure is performed on the cylindrical section of the shell, all of the shell, including the domed sections, shall be as resistant to the exposure environments as are the exposed areas. As an alternative, a single cylinder approach may be used in which both the immersion test and the other fluid exposure test may be carried out on one cylinder as indicated in Table B.1. In this case, care shall be taken to prevent cross contamination among the fluids.

B.1.2 Preconditioning

B.1.2.1 Preconditioning apparatus

The following types of apparatus shall be used for preconditioning the test shell by pendulum and gravel impact.

The pendulum impact apparatus shall comprise:

- a) a steel impact body having the shape of a pyramid with equilateral triangle faces and a square base, the summit and the edges being rounded to a radius of 3 mm;
- b) a pendulum, the centre of percussion of which coincides with the centre of gravity of the pyramid; its distance from the axis of rotation of the pendulum being 1 m and the total mass of the pendulum referred to its centre of percussion being 15 kg;
- c) a means of determining that the energy of the pendulum at the moment of impact is not less than 30 N·m and is as close to that value as possible;
- d) a means of holding the shell in position by the end bosses during impact.

The gravel impact machine shall comprise:

- a) an impact machine, constructed according to the design specifications shown in Figure B.1 and capable of being operated in accordance with ASTM D3170 except that the shell may be at ambient temperature during gravel impact;
- b) gravel, comprising alluvial road gravel passing through a 16 mm space screen but retained on a 9,5 mm space screen. Each application shall consist of 550 ml of graded gravel (approximately 250 to 300 stones).

Dimensions in millimetres

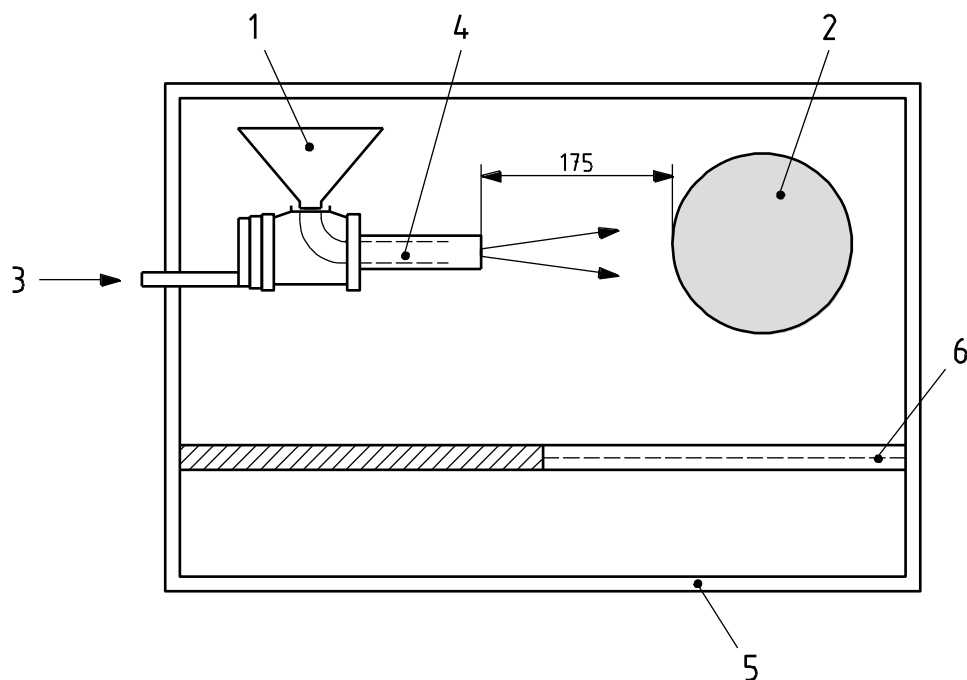

2

3 **Key**

- 4 1 funnel
 5 2 shell under test
 6 3 air inlet
 7 4 50 mm pipe
 8 5 cabinet approximately 500 mm wide
 9 6 sizing screen

10

Figure B.1 — Gravel impact machine

11 **B.1.2.2 Preconditioning procedure**12 **B.1.2.2.1 Preconditioning for the immersion test**

13 Preconditioning by both pendulum impact and gravel impact shall be carried out on the portion of the shell to
 14 be used for the immersion test (see B.1.3.1).

15 With the shell unpressurized, precondition the central section of the shell that will be submerged, by an impact
 16 of the pendulum body at three locations spaced approximately 150 mm apart. Following the pendulum impact,
 17 precondition each of the three locations by gravel impact application. Additionally, precondition by a single
 18 impact of the pendulum body a location within the submerged portion of each domed section and 50 mm
 19 (measured axially) from the tangent.

20 **B.1.2.2.2 Preconditioning for the other fluid exposure test**

21 Preconditioning by gravel impact only shall be carried out on the portion of the shell to be used for the other
 22 fluid exposure test (see B.1.3.2).

23 Divide the upper section of the cylinder used for the other fluid exposure test into five distinct areas of a
 24 nominal diameter 100 mm and mark these for preconditioning and fluid exposure (see Figure B.2). Ensure
 25 that the areas do not overlap on the shell surface. If the single shell approach is used, also ensure that these
 26 areas do not overlap with the section of the shell that will be subjected to the immersion test. While convenient
 27 for testing, the areas need not be oriented along a single line.

1 With the shell unpressurized, precondition each of the five marked areas identified as per the above
 2 instructions (see Figure B.2) for the other fluid exposure test by gravel impact application.

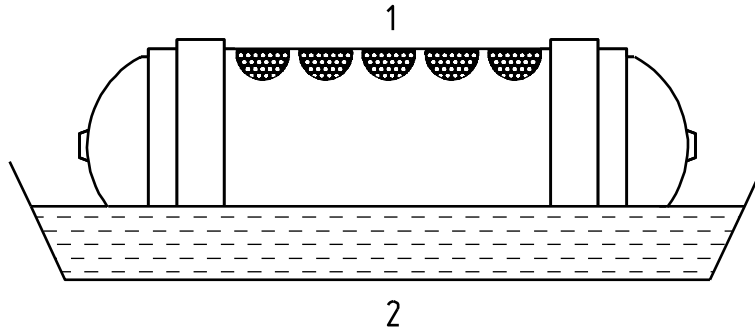

3

4 **Key**

- 5 1 other fluid exposure area
 6 2 immersion area (lower third)

7

Figure B.2 — Cylinder orientation and layout of exposure areas

8 **B.1.3 Test conditions**

9 **B.1.3.1 Immersion test**

10 At the appropriate stages in the test sequence (see Table B.1), orient the shell horizontally to immerse the
 11 lower third of the shell diameter in a simulated acid rain/road salt water solution composed of the following
 12 compounds:

- 13 — deionized water;
- 14 — a mass fraction of $(2,5 \pm 0,1)$ % of sodium chloride;
- 15 — a mass fraction of $(2,5 \pm 0,1)$ % of calcium chloride;
- 16 — sulfuric acid in sufficient quantity to achieve a solution pH of $4,0 \pm 0,2$.

17 Adjust the solution level and pH prior to each step of the immersion test.

18 Maintain the temperature of the bath at (21 ± 5) °C. During immersion, hold the unsubmerged section of the
 19 shell in ambient air.

20 **B.1.3.2 Other fluid exposure**

21 At the appropriate stages in the test sequence (see Table B.1), expose each marked area to one of five test
 22 solutions described below . Use the same test solution for each location throughout the test.

- 23 — an aqueous solution with a minimum volume fraction of 19 % of sulfuric acid;
- 24 — an aqueous solution with a minimum mass fraction of 25 % sodium hydroxide;
- 25 — a volume fraction of 30 % methanol in gasoline;
- 26 — an aqueous solution with a minimum mass fraction of 28 % ammonium nitrate;
- 27 — an aqueous solution with a minimum volume fraction of 50 % methyl alcohol (i.e. windscreen washer
 28 fluid).

1 During the exposure, orient the test cylinder with the exposure area uppermost. Place a pad of glass wool
 2 approximately 0,5 mm thick and 100 mm in diameter on each of the preconditioned areas. Using a pipette,
 3 apply 5 ml of the test solution to the glass wool pad. Ensure that the glass wool pad is wetted evenly across its
 4 surface and through its thickness. Pressurize the shell and remove the glass wool pad after pressurization for
 5 30 min.

6 B.1.3.3 Pressure cycle

7 At the appropriate stage in the test sequence (see Table B.1), subject the shell to hydraulic or pneumatic
 8 pressure cycles of between 5 % MDP and MDP for the ambient and high temperature steps, and between
 9 5 % MDP and 60 % MDP for the lower temperature steps. Hold the maximum pressure for a minimum of 60 s
 10 and ensure that each full cycle takes no less than 66 s.

11 B.1.3.4 High and low temperature exposure

12 At the appropriate stages in the test sequence (see Table B.1), bring the surface of the shell to a high or low
 13 temperature in air. The low temperature shall be no higher than $-35\text{ }^{\circ}\text{C}$ and the high temperature shall be at
 14 minimum the maximum service temperature ($65\text{ }^{\circ}\text{C}$ or greater) as measured on the surface of the shell.

15 B.1.4 Test procedure

16 Precondition the shells (or shell in the single shell approach) in accordance with B.1.2.

17 Carry out the sequences of fluid, pressure cycling and temperature exposure as defined in Table B.1. Do not
 18 wash or wipe the shell surface between stages;

19 **Table B.1 — Test conditions and sequence**

Test steps			Environments	Number of pressure cycles	Temperature
Two shell approach		Single shell approach			
Shell no.1	Shell no. 2	Alternative single shell			
—	1	1	other fluids (30 min)	—	ambient
1	—	2	immersion	500 x service life (years)	ambient
—	2	—	air	250 x service life (years)	ambient
—	3	3	other fluids (30 min)	—	ambient
2	4	4	air	250 x service life (years)	low
—	5	5	other fluids (30 min)	—	ambient
3	6	6	air	250 x service life (years)	high

20 Following completion of the sequences, all MH assemblies shall be pressurized to destruction as per 6.2.4.4.2
 21 or 6.2.4.4.3 and meet the acceptance criteria.

1 **B.2 Salt water immersion test**

2 **B.2.1 General**

3 This test is mandatory for all MH assemblies intended for underwater discharging/refilling or underwater
4 applications. It is optional for other uses.

5 **B.2.2 Set-up**

6 The shell shall be unpainted but otherwise finished as for the intended application.

7 For shells comprised of Type II and Type III fibre-wrapped cylinders, the liner may be painted or protected
8 from corrosion in any manner that is included in the design submission.

9 **B.2.3 Immersion period**

10 Two closed unpressurized shells shall be immersed for a period of between 1 h and 2 h in a well aerated
11 aqueous solution containing at least 35 g/l of sodium chloride at a temperature not less than 20 °C.

12 After 2 h, the pressure of the shell shall be increased to and maintained at five-sixths the MDP for not less
13 than 22 h. Pressure is then to be released.

14 **B.2.4 Drying period**

15 After the immersion period, the shells shall be taken out from the sodium chloride solution and subjected to
16 natural drying conditions in ambient atmosphere for not less than 22 h.

17 The pressure of the shell shall be increased to and maintained at five-sixths the MDP for not less than 2 h.
18 Pressure is then to be released.

19 **B.2.5 Duration of test and acceptance criteria**

20 The cycle consisting of the immersion and the drying period as per B.2.3 and B.2.4 shall be repeated 45 times.

21 On completion of the test, one of the two shells shall be pressurized to destruction as per 6.2.4.4.2 or
22 6.2.4.4.3 and meet the acceptance criteria. The other shell shall be subjected to the ambient cycle test of
23 ISO 11119-2:2002, 8.5.5, and withstand 3 000 pressurization cycles at five-sixths the MDP without failure by
24 burst or leakage.

25 The following parameters shall be monitored during the test and recorded:

26 a) the temperature of the sodium chloride solution, at least once a day;

27 b) the test pressure;

28 c) the duration of immersion;

29 d) the parameters specified in 6.2.4.4.2 or 6.2.4.4.3;

30 e) the parameters specified in ISO 11119-2:2002, 8.5.5.

31

1 **Annex C**
2 (informative)

3
4 **Type approval certificate**

5 This annex provides an example of a suitable form of a type approval certificate. Other formats are also
6 acceptable.

7 **TYPE APPROVAL CERTIFICATE**

8 Issued by
9 (Authorized inspection authority)

10
11 applying ISO 16111:2008 concerning

12 **Metal hydride (MH) assemblies**

13 Approval no. Date

14 MH assembly design:

15 [Description of the family of MH assembly (drawing no.) which has received type approval]

16 **MH assembly description and design criteria:**

17 Maximum developed pressure (MDP): bar

18 Stress level at MDP: bar

19 Rated charging pressure (RCP): bar

20 Rated hydrogen capacity: g

21 Operating temperature range: °C

22 Service temperature range: °C

23 Service life: years

24 Number, location, size, flow capacity and type of pressure relief device (PRD):

25 PRD activation pressure (as applicable): bar

26 PRD activation temperature (as applicable): °C

27 Hydrogen absorbing alloy:

28 Means of solid particulate containment (as applicable):

29 Internal component (as applicable):

30 Exterior coating (as applicable):

31 Cooling system (as applicable):

32 **Shell description and design criteria³⁾:**

33 Design and Construction Standard (e.g. ISO 9809-1):

34 Test pressure, p_h : bar Outside diameter (nominal): mm

35 Minimum guaranteed wall thickness, a' : mm

36 Shape of base:

37 Length (nominal): mm Water capacity (nominal): l

38 Heat treatment:

39 Material type and properties: Material: R_e : MPa R_g : MPa

3) Need not be completed if shell manufacturer's drawing and acceptance certificate are attached.

1 **MH assembly manufacturer or agent**

2
3 (Name and address of MH assembly manufacturer or its agent)
4
5
6

7 All information may be obtained from:

8
9 (Name and address of approving body)

10 I hereby certify that I have determined that the MH assembly design described on this type approval certificate
11 complies in all respects to ISO 16111:2008. The type test reports are attached hereto.

12
13 Date Place

14
15 Signature of inspector

16

Annex D
(informative)

Acceptance certificate

5 This annex provides an example of a suitable form of acceptance certificate. Other formats are also
6 acceptable.

ACCEPTANCE CERTIFICATE

Acceptance certificate no.: for metal hydride assemblies

9 A consignment of MH assemblies consisting of batches has been inspected and tested in
10 accordance with ISO 16111.

11 Manufacturer of MH assembly:

12 Location:

13 Quantity:

14 Test date (month, year):

15 Shell manufacturer:

16 Location: Batch number(s):

TECHNICAL DATA

Water capacity: nominal	_____ l	Nominal length (without cap and without valve):	_____ mm
Test pressure of shell, p_h :	_____ bar	Nominal outside diameter, D :	_____ mm
Minimum burst pressure of shell:	_____ bar	Design and construction standard for shell:	_____
Maximum developed pressure (MDP):	_____ bar	Stress level at MDP:	_____ MPa
Rated charging pressure (RCP):	_____ bar	Minimum guaranteed wall thickness of shell, a' :	_____ mm
Rated hydrogen capacity:	_____ g	Drawing no.:	
Operating temperature range:	_____ °C	Service temperature range:	_____ °C
Pressure relief device(s) type, number, location:	_____	Service life:	_____ years

18
19
20

Markings⁴⁾:

.....

Date

The manufacturer

21
22

4) To be quoted or drawing to be attached.

ACCEPTANCE TESTS

My record of tests and inspection for each batch of MH assemblies covered by this certificate is as follows⁵⁾:

Shell-batch number	Covering serial Nos. to	Burst Test	
		Burst Pressure, bar	Enter "Pass " or "Fail"

The above results represent sample MH assemblies selected from each batch. All other MH assemblies in the batch were subjected to a leak test at (enter temperature) °C, pressurized to RCP, and met the applicable acceptance criteria of clause 6.2.5 of ISO 16111.

A certified report of manufacture and test of the shells (acceptance certificate) is attached hereto.

Hydride-batch number	Covering serial Nos. to	MDP Test	
		Maximum Developed Pressure, bar	Enter "Pass " or "Fail"

The above results represent sample MH assemblies selected from each batch. All other MH assemblies in the batch were subjected to a leak test at (enter temperature) °C, pressurized to RCP, and met the applicable acceptance criteria of clause 6.2.5 of ISO 16111.

A certified report of manufacture and test of the shells (acceptance certificate) is attached hereto. I hereby certify that the MH assemblies described on this acceptance certificate comply with the requirements of International Standard ISO 16111.

Special remarks:

.....

.....

5) Need not be filled in if test reports are attached.

1 On behalf of:

2

3

Date

Signature of inspector

4

Annex E
(informative)

Shell having internal volume greater than 150L

In the absence of ISO Standard dedicated to hydride systems with internal volumes higher than 150L and lower than 3000L having MDP lower than 250 bar, the present Standard can be used as a guideline. In such cases, requirements of this standard may need to be modified to account for the size, geometry and/or application of larger systems.

Due to their relatively large mass and size, vessels described in this Annex are generally considered to be transportable only by fixing them to a moveable structure such as a trailer or hand truck. As such, when using this Standard for guidance, users shall take into account the means of transport and the environment the storage system will be subjected to.

In addition to those listed in Section 5.3, the MH Assembly shell may also be designed and tested in accordance with ISO 11120.

MH Assemblies described in this Annex may be designed for different operating regimes than envisioned in the scope of ISO16111. Therefore, in agreement with competent authority of the country of use, the manufacturer may use engineering judgment and calculations to modify the testing regime as required to demonstrate that design meets the intent of this Standard. In cases where physical testing is not feasible due to size, geometry or safety considerations, modeling may be used as an alternative means of demonstrating ability to meet a given requirement.

Annex F (informative)

Fixed fuel-storage onboard hydrogen fueled vehicles

5 In the absence of ISO Standard dedicated to storage MH assemblies intended to be used as fixed fuel-
6 storage onboard hydrogen fueled vehicles having MDP lower than 250 bar, the present Standard can be used
7 as a guideline. In such cases, requirements of this standard may need to be modified to account for the
8 conditions of use

9 Due to their use, vessels described in this Annex are generally considered to be transportable only by fixing
10 them to the vehicle structures such as car, truck, train, boat,... As such, when using this standard for guidance,
11 users shall take into account the means of transport and the environment the storage system will be subjected
12 to.

13 The normal operating temperature shall be included in the service condition temperature range. The service
14 temperature range is at minimum (-40°C,+85°C).

15 In addition to the standard listed in Section 5.3, the manufacturer **may also** test the shell in accordance to the
16 national regulation of the country of used related to onboard hydrogen fuelled vehicles or the UN Global
17 Technical Regulation No.13 (Hydrogen and fuel cell vehicles).

18 MH Assemblies described in this Annex may be designed for different operating regimes than envisioned in
19 the scope of ISO16111. Therefore, in agreement with competent authority of the country of use, the
20 manufacturer may use engineering judgment and calculations to modify the testing regime as required to
21 demonstrate that design meets the intent of this Standard. In cases where physical testing is not feasible due
22 to size, geometry or safety considerations, modeling may be used as an alternative means of demonstrating
23 ability to meet a given requirement.

Annex G (informative)

Stationary application

In the absence of ISO Standard dedicated to hydride systems for stationary application (i.e. hydride system that are not used to transport hydrogen itself, that means hydrogen systems that are used to store and release hydrogen once installed and integrated in a stationary hydrogen chain, without being move during or in-between these operations), the present Standard can be used as a guideline.

In such cases, requirements of this standard may need to be modified to account for the size, geometry and/or application of larger systems.

In addition to those listed in Section 5.3.1, when volume is higher of 150l the MH Assembly shell may also be designed and tested in accordance with ISO 11120.

Some of the requirements of the present standard are not mandatory for stationary applications:

- Concerning the drop test (§6.2.4.3), there is no need to perform this kind of test. If the MH assembly is dropped during handling or transportation, it should not be used, and returned to manufacturer for requalification/recertification.
- It is not necessary for the MH assembly to be tested as per Section 6.2.6 in configurations/orientations other than the position it will occupy during its stationary use.
- It is not necessary to perform the shut-off valve impact test (§6.2.7), as long as the shut-off valve is well protected against external impact, during transportation and operation of the MH assembly.

Comment: During transportation the free hydrogen gas shall be removed from the MH assembly and replaced with an inert gas such as Argon.

MH Assemblies described in this Annex may be designed for different operating regimes than envisioned in the scope of ISO16111. Therefore, in agreement with competent authority of the country of use, the manufacturer may use engineering judgment and calculations to modify the testing regime as required to demonstrate that design meets the intent of this Standard. In cases where physical testing is not feasible due to size, geometry or safety considerations, modeling may be used as an alternative means of demonstrating ability to meet a given requirement.

1

Bibliography

- 2 [1] ISO 2626, *Copper — Hydrogen embrittlement test*
- 3 [2] ISO 3690, *Welding and allied processes — Determination of hydrogen content in ferritic steel arc weld*
4 *metal*
- 5 [3] ISO 6406, *Gas cylinders — Seamless steel gas cylinders — Periodic inspection and testing*
- 6 [4] ISO 7539-6, *Corrosion of metals and alloys — Stress corrosion testing — Part 6: Preparation and use*
7 *of pre-cracked specimens for tests under constant load or constant displacement*
- 8 [5] ISO 9587, *Metallic and other inorganic coatings — Pretreatment of iron or steel to reduce the risk of*
9 *hydrogen embrittlement*
- 10 [6] ISO 9588, *Metallic and other inorganic coatings — Post-coating treatments of iron or steel to reduce*
11 *the risk of hydrogen embrittlement*
- 12 [7] ISO 10461, *Gas cylinders — Seamless aluminium-alloy gas cylinders — Periodic inspection and*
13 *testing*
- 14 [8] ISO 11114-1, *Transportable gas cylinders — Compatibility of cylinder and valve materials with gas*
15 *content — Part 1: Metallic materials*
- 16 [9] ISO 11114-2, *Transportable gas cylinders — Compatibility of cylinder and valve materials with gas*
17 *contents — Part 2: Non-metallic materials*
- 18 [10] ISO 11623, *Transportable gas cylinders — Periodic inspection and testing of composite gas cylinders*
- 19 [11] ISO 15330, *Fasteners — Preloading test for the detection of hydrogen embrittlement — Parallel*
20 *bearing surface method*
- 21 [12] ISO 15724, *Metallic and other inorganic coatings — Electrochemical measurement of diffusible*
22 *hydrogen in steels — Barnacle electrode method*
- 23 [13] ISO/TR 15916, *Basic considerations for the safety of hydrogen systems*
- 24 [14] ISO 17081, *Method of measurement of hydrogen permeation and determination of hydrogen uptake*
25 *and transport in metals by an electrochemical technique*
- 26 [15] ANSI/AIAA G-095-2004, *Guide to Safety of Hydrogen and Hydrogen Systems*
- 27 [16] API RP 934, *Materials and Fabrication Requirements for 2 1/4 Cr-1Mo and 3Cr-1Mo Steel Heavy Wall*
28 *Pressure Vessels for High Temperature, High Pressure Hydrogen Service*
- 29 [17] API RP 941, *Steels for Hydrogen Service at Elevated Temperatures and Pressures in Petroleum*
30 *Refineries and Petrochemical Plants*
- 31 [18] ASTM B57, *Standard Test Methods for Detection of Cuprous Oxide (Hydrogen Embrittlement*
32 *Susceptibility) in Copper*
- 33 [19] ASTM B849, *Standard Specification for Pre-Treatments of Iron or Steel for Reducing Risk of Hydrogen*
34 *Embrittlement*
- 35 [20] ASTM B850, *Standard Guide for Post-Coating Treatments of Steel for Reducing the Risk of Hydrogen*
36 *Embrittlement*

- 1 [21] ASTM B839, *Standard Test Method for Residual Embrittlement in Metallic Coated, Externally*
2 *Threaded Articles, Fasteners, and Rod-Inclined Wedge Method*
- 3 [22] ASTM E1681, *Standard Test Method for Determining a Threshold Stress Intensity Factor for*
4 *Environment-Assisted Cracking of Metallic Materials*
- 5 [23] ASTM F326, *Standard Test Method for Electronic Measurement for Hydrogen Embrittlement from*
6 *Cadmium-Electroplating Processes*
- 7 [24] ASTM F519, *Standard Test Method for Mechanical Hydrogen Embrittlement Evaluation of Plating*
8 *Processes and Service Environments*
- 9 [25] ASTM F1459, *Standard Test Method for Determination of the Susceptibility of Metallic Materials to*
10 *Hydrogen Gas Embrittlement*
- 11 [26] ASTM F1624, *Standard Test Method for Measurement of Hydrogen Embrittlement Threshold in Steel*
12 *by the Incremental Step Loading Technique*
- 13 [27] ASTM F1940, *Standard Test Method for Process Control Verification to Prevent Hydrogen*
14 *Embrittlement in Plated or Coated Fasteners*
- 15 [28] ASTM F2078, *Standard Terminology Relating to Hydrogen Embrittlement Testing*
- 16 [29] ASTM G129, *Standard Practice for Slow Strain Rate Testing to Evaluate the Susceptibility of Metallic*
17 *Materials to Environmentally Assisted Cracking*
- 18 [30] ASTM G142, *Standard Test Method for Determination of Susceptibility of Metals to Embrittlement in*
19 *Hydrogen Containing Environments at High Pressure, High Temperature, or Both*
- 20 [31] ASTM G146, *Standard Practice for Evaluation of Disbonding of Bimetallic Stainless Alloy/Steel Plate*
21 *for Use in High-Pressure, High-Temperature Refinery Hydrogen Service*
- 22 [32] ASTM G148, *Standard Practice for Evaluation of Hydrogen Uptake, Permeation, and Transport in*
23 *Metals by an Electrochemical Technique*
- 24 [33] ASME *Boiler and Pressure Vessel Code*
- 25 [34] ASME B31.1, *Power piping*
- 26 [35] ASME B31.3, *Process piping*
- 27 [36] ANSI/AWS A4.3, *Standard Methods for Determination of the Diffusible Hydrogen Content of*
28 *Martensitic, Bainitic, and Ferritic Steel Weld Metal Produced by Arc Welding*
- 29 [37] SAE/AMS 2451/4, *Plating, Brush, Cadmium — Corrosion Protective, Low Hydrogen Embrittlement*
- 30 [38] SAE/AMS 2759/9, *Hydrogen Embrittlement Relief (Baking) of Steel Parts*
- 31 [39] SAE/USCAR 5-1, *Avoidance of Hydrogen Embrittlement of Steel*
- 32 [40] NACE TM0177, *Laboratory Testing of Metals for Resistance to Sulfide Stress Cracking and Stress*
33 *Corrosion Cracking in H₂S Environments*
- 34 [41] NACE TM0284, *Evaluation of Pipeline and Pressure Vessel Steels for Resistance to Hydrogen-*
35 *Induced Cracking*